



# **bc627AT**

# **GPS Satellite Receiver**

# **Addendum**

Revision B

User's Guide

8500-0012

March, 2004

**bc627AT**  
**GPS SATELLITE RECEIVER ADDENDUM**

**TABLE OF CONTENTS**

<b>SECTION</b>	<b>PAGE</b>
<b>CHAPTER ONE</b>	
<b>GENERAL</b>	
1.0 General.....	1-1
1.1 GPS Overview .....	1-2
1.2 Antenna Position.....	1-2
<b>CHAPTER TWO</b>	
<b>SELECTING GPS MODE</b>	
2.0 Selecting GPS Mode.....	2-1
2.1 Mode 0 .....	2-1
2.2 Mode 1 .....	2-1
2.3 Mode 3, and Mode 4 .....	2-1
<b>CHAPTER THREE</b>	
<b>COMMUNICATING WITH THE ACUTIME</b>	
3.0 Communicating with the Acutime.....	3-1
<b>CHAPTER FOUR</b>	
<b>ADDITIONAL bc620AT MODE FOUR CONSIDERATIONS</b>	
4.0 Additional bc620AT Mode 4 Considerations.....	4-1
4.1 Selected Defaults (Loaded by bc620AT Firmware at Boot) .....	4-1
4.1.1 Packet 35H (I/O Options) 2, 2, 1, 0 .....	4-1
4.1.2 Packet 2CH (Operating Parameters).....	4-1
<b>CHAPTER FIVE</b>	
<b>TRIMBLE STANDARD INTERFACE PROTOCOL</b>	
5.0 Introduction.....	5-1
5.1 Interface Scope .....	5-1
5.2 Key Acutime Setup Parameters .....	5-2
5.2.1 Fix Mode.....	5-4

## TABLE OF CONTENTS

5.2.2 Operating Parameters.....	5-4
5.2.2.1 Dynamics Code.....	5-4
5.2.2.2 Elevation Mask.....	5-5
5.2.2.3 Signal Level Mask.....	5-5
5.2.2.4 PDOP Mask and Switch.....	5-5
5.2.3 Time of Fix Parameters.....	5-5
5.2.3.1 Default Mode.....	5-6
5.2.3.2 Integer Second.....	5-6
5.2.3.3 Minimized Projection.....	5-6
5.2.4 Synchronized Measurements.....	5-6
5.2.5 Additional Fix Status.....	5-7
5.2.6 DGPS Mode.....	5-7

### CHAPTER SIX APPLICABLE DOCUMENTS

6.0 Applicable Documents.....	6-1
-------------------------------	-----

### CHAPTER SEVEN SIGNAL CHARACTERISTICS

7.0 Signal Characteristics.....	7-1
7.1 General.....	7-1
7.2 Packet Data Format.....	7-1
7.3 Packet Structure.....	7-2
7.3.1 Packets Sent by the User to Acutime.....	7-3
7.3.1.1 ID Clear Oscillator Offset.....	7-5
7.3.1.2 IE Clear Battery Back-up, then Reset.....	7-5
7.3.1.3 IF Request Software Versions.....	7-5
7.3.1.4 20 Request Software Versions.....	7-5
7.3.1.5 21 Request Current Time.....	7-5
7.3.1.6 22 Position Fix Mode Select.....	7-6
7.3.1.7 23 Initial Position (XYZ Cartesian ECEF).....	7-6
7.3.1.8 24 Request Acutime Position Fix Mode.....	7-7
7.3.1.9 25 Initiate Soft Reset and Self Test.....	7-7
7.3.1.10 26 Request Health.....	7-7
7.3.1.11 27 Request Signal Levels.....	7-7
7.3.1.12 28 Request GPS System Message.....	7-7
7.3.1.13 29 Request Almanac Health Page.....	7-7
7.3.1.14 2A Altitude for 2-D Mode.....	7-7
7.3.1.15 2B Initial Position (Latitude, Longitude, Altitude).....	7-8
7.3.1.16 2C Set/Request Operating Parameters.....	7-8

**TABLE OF CONTENTS**

7.3.1.17 2D Request Oscillator Offset ..... 7-9

7.3.1.18 2E Set GPS Time ..... 7-10

7.3.1.19 31 Accurate Initial Position (XYZ Cartesian ECEF)..... 7-10

7.3.1.20 32 Accurate Initial Position (Latitude, Longitude, Altitude)..... 7-10

7.3.1.21 33 Request A-to-D Readings ..... 7-10

7.3.1.22 34 Satellite Number for One Satellite Mode ..... 7-10

7.3.1.23 35 Set/Request I/O Options ..... 7-11

7.3.1.24 36 Velocity Aiding of Acquisition..... 7-13

7.3.1.25 37 Request Status and Values of Last Position and Velocity ..... 7-14

7.3.1.26 38 Request/Load Satellite System Data..... 7-14

7.3.1.27 39 Set/Request Satellite Disable or Ignore Health ..... 7-15

7.3.1.28 3A Request Last Raw Measurement..... 7-16

7.3.1.29 3B Request Current Status of Satellite Ephemeris Data..... 7-17

7.3.1.30 3C Request Current Satellite Tracking Status ..... 7-17

7.3.1.31 3D Request/ Set Data Channel A Configuration for Differential Corrections 7-17

7.3.1.32 3E Request Additional Fix Parameters ..... 7-19

7.3.1.33 62 Request/Set Differential Position Fix Mode..... 7-19

7.3.1.34 65 Request Differential Correction Status ..... 7-19

7.3.1.35 75 Set/Request Best 4/High6/Smart 8 Modes..... 7-20

7.3.2 Packets Sent by Acutime to the User ..... 7-20

7.3.2.1 40 Almanac Data Page..... 7-22

7.3.2.2 41 GPS Time..... 7-23

7.3.2.3 42 Single Precision Position Fix, XYZ ECEF ..... 7-23

7.3.2.4 43 Velocity Fix, XYZ ECEF ..... 7-24

7.3.2.5 44 Satellite Selection ..... 7-24

7.3.2.6 45 Software Version Information ..... 7-25

7.3.2.7 46 Health of Acutime..... 7-26

7.3.2.8 47 Signal Levels for all Satellites ..... 7-27

7.3.2.9 48 GPS System Message ..... 7-27

7.3.2.10 49 Almanac Health Page..... 7-28

7.3.2.11 4A Single Precision LLA Position Fix ..... 7-28

7.3.2.12 4B Machine/Code ID and Additional Status ..... 7-29

7.3.2.13 4C Report Operating Parameters ..... 7-30

7.3.2.14 4D Oscillator Offset..... 7-31

7.3.2.15 4E Response to Set GPS Time..... 7-31

7.3.2.16 54 One Satellite Bias and Bias Rate ..... 7-31

7.3.2.17 55 I/O Options ..... 7-32

7.3.2.18 56 Velocity Fix, East-North-Up (ENU)..... 7-34

7.3.2.19 57 Information About Last Computed Fix..... 7-35

7.3.2.20 58 Satellite System Data/Acknowledge from Acutime ..... 7-35

7.3.2.21 59 Status of Satellite Disable or Ignore Health..... 7-36

7.3.2.22 5A Raw Measurement Data..... 7-37

## TABLE OF CONTENTS

7.3.2.23	5B Satellite Ephemeris Status.....	7-38
7.3.2.24	5C Satellite Tracking Status .....	7-39
7.3.2.25	5E Additional Fix Status.....	7-42
7.3.2.26	5F Failure Report.....	7-42
7.3.2.27	6D All-in-View Satellite Selection.....	7-42
7.3.2.28	76 Best 4/High 6/Smart 8 Mode .....	7-43
7.3.2.29	82 Differential Position Fix Mode.....	7-43
7.3.2.30	83 Double Precision XYZ Position Fix and Bias Information .....	7-44
7.3.2.31	84 Double Precision LLA Position Fix and Bias Information.....	7-44
7.3.2.32	85 Differential Corrections Status .....	7-45

## CHAPTER EIGHT APPLICATION NOTES

8.0	General.....	8-1
8.1	Introduction.....	8-4
8.2	General Description .....	8-5
8.3	System Definition .....	8-5
8.3.1	General Functional Description .....	8-5
8.3.2	Abbreviated Specifications .....	8-6
8.4	System Component Description .....	8-10

## CHAPTER NINE PACKETS

9.0	General.....	9-1
9.1	Packet “M” - UTC Local Time Offset.....	9-1
9.2	Packet “N” - GPS Leap Seconds .....	9-1
9.3	Packet “O” - Request bc627AT Data .....	9-2
9.4	Packet “o” - bc627AT Data Return Packet.....	9-2
9.5	Packet “P” - Path Selection.....	9-3

## CHAPTER TEN ANTENNA MOUNTING

10.0	Antenna Mounting.....	10-1
------	-----------------------	------

## CHAPTER ONE

### GENERAL

#### 1.0 GENERAL

The bc627AT GPS Satellite Receiver Addendum consists of a bc620AT Time and Frequency Module (hereafter termed bc620 for brevity) and a GPS receiver core module. The GPS receiver module is manufactured by Trimble Navigation Ltd. in Sunnyvale, CA, and is designated as the Acutime Six Channel GPS Smart Antenna. The current generation of the Acutime is a six channel C/A code receiver and antenna integrated in a compact weatherproof housing which mounts like an antenna.

This User's Guide is supplied with a complete bc620 User's Guide and is only intended to describe features that are unique to the GPS receiver implementation.

The interface to the bc620AT with the Acutime GPS option is identical to the bc620AT interface described in the User's Guide for that module. An additional data packet has been added which allows direct communication to the Acutime.

**Table One**  
**Acutime Performance Summary**

<b>Item</b>	<b>Description</b>
Number of Channels	Six
Receiver Frequency	1.575 GHz C/A Code
Time to First Fix 1> Brief Power Off 2> Needs Ephemeris 3> Needs Almanac	1.5 Minutes 3.5 Minutes Five to Fifteen Minutes
Dynamics 1> Velocity 2> Acceleration 3> Jerk	300 Meters/Sec (600 Knots) 19.5 m/s/s (2 g's) 20 m/s/s/s
Position Accuracy	25 Meters CEP (PDOP <6)
Velocity Accuracy	0.2 Meters/Sec (PDOP <6)
1pps Accuracy	+/- One Microsecond
Solution Modes Four Satellite Three Satellite one Satellite	3-D Position, Velocity, and Time 3-D Position, Velocity, and Time, (Altitude Hold) Static Position Time Only
Auto	One, Three, and Four Satellite Auto Transitions
Power	+12VDC at 0.2 Amp

## CHAPTER ONE

### 1.1 GPS OVERVIEW

The GPS system consists of three parts called segments:

- The space segment consists of eighteen satellites and three spares broadcasting the radio navigation signals.
- The control segment tracks the satellites and uploads orbital information (ephemerides) and clock corrections. There are five monitor stations, three up-link stations, and one master control station.
- The user segment tracks and receives the radio navigation signals and computes user position and time.

The signals transmitted from the satellites consist of two modulated carriers: L1 at 1.575 GHz and L2 at 1.227 GHz. The L1 signal is modulated with both a C/A code and a P code. The L2 signal is modulated with a P code only. Civilian access to the system is provided through the C/A code. The P code is intended for authorized military users only. The bc620AT/Acutime operates on the C/A code.

The bc620AT determines time and position by measuring the time of arrival of the satellite signals. If the user has no knowledge of either time or position, then four satellites are required to determine a solution for the four unknown quantities X, Y, Z and time. If position is known and static, then time can be determined by measuring the time of arrival of a single satellite signal. Each satellite broadcasts information, which allows the user to calculate the position of the satellite. Knowledge of this position, the user position, and a model of the transmission path characteristics allow accurate time determination.

The structure and content of the satellite signals and the decoding and solution determination algorithms are beyond the scope of this User's Guide. Further information may be obtained from the paperback overview "Guide to GPS Positioning" prepared by David Wells and published by the Canadian GPS Associates.

### 1.2 ANTENNA POSITION

The most common difficulty encountered using GPS equipment is user antenna position. The GPS antenna must be located in an area, which has a clear view of the sky. The GPS signals cannot penetrate foliage or structures. It is strongly recommended that the user take the time to properly position the antenna.

## **CHAPTER TWO**

---

### **SELECTING GPS MODE**

#### **2.0 SELECTING GPS MODE**

Historically (based on customer feedback with other GPS instruments) one of the most confusing aspects of operation is the selection of the GPS mode (not to be confused with the bc620AT mode). The bc620AT/Acutime supports four GPS modes of operation.

##### **2.1 MODE 0**

This mode uses as many satellites as are available to perform both position fixes and timing functions. Confusion arises because this mode selection interacts with the dynamics code selection. If a non-static dynamics code is selected, only three or four satellites will be used because the GPS sensor assumes that it is moving. If only three satellites are usable, altitude will be held constant. If a static dynamics code is entered, mode 0 will use three or four satellites for a navigation solution as previously. However, if only one or two satellites are available, the sensor will use the satellite with highest elevation to continue calculating bias and bias rate (the timing functions will continue unimpaired). It is very advantageous, therefore, to enter a static dynamics code if the sensor is static.

##### **2.2 MODE 1**

A new mode has been added to the receiver which allows a directed satellite to be used for timing functions. If mode 1 is selected, only a single satellite will be used for timing, and the current position will be assumed accurate and static.

A new data packet, 34, has been added which allows the satellite associated with mode 1 to be selected. This packet has 1 data byte which specifies the PRN of the desired satellite. If a data byte value of 0 is entered, then the sensor will always track the single satellite which has the highest elevation within the constellation in view.

It is very advantageous to operate in a single satellite highest elevation mode for timing applications. The greatest contribution to timing error is the electron content variation in the path between the satellite and the receiver. This variation is minimized by selecting the highest elevation satellite.

##### **2.3 MODE 3 AND MODE 4**

These modes are rarely used for timing applications unless the user operation platform is dynamic. Mode 3 is particularly useful in a marine environment where the sensor altitude is relatively constant.



This Page Intentionally Left Blank.

## CHAPTER THREE

---

### COMMUNICATING WITH THE ACUTIME

#### 3.0 COMMUNICATING WITH THE ACUTIME

Communication with the Acutime module is implemented with a pair of FIFO's, an input FIFO and an output FIFO. Input packets are placed in the INFIFO at offset 0xE. Output data packets are read from the OUTFIFO at the same offset.

Input data packets must be in the following format shown below. (See the bc620AT User's Guide, for a general discussion of the input FIFO protocol.)

byte 1	0x01	Start of Header (SOH)
byte 2	"J"	Packet ID Byte (ASCII "J")
byte 3	0x17	End of Transmission Block (ETB)
byte 4		TANS Packet Data
.		.
.		.
.		.
byte N		Last packet byte (0x03)

After loading the INFIFO with one complete data packet, the user must direct the bc620AT to take action on the packet by writing to the ACK register with bit 7 set to one. The 620AT firmware will set bit 0 of the ACK register every time a valid data packet has been received and processed. It is the user's responsibility to clear this bit as described in the bc620AT User's Guide.

Acutime output data packets are placed in the output FIFO exactly as they are produced by the Acutime whenever the Acutime GPS mode is enabled (mode 4). The input and output FIFO's are effectively I/O pipelines to the Acutime RS-422 channel. When the GPS sensor mode is not enabled the Acutime output packets are ignored, and any input "J" packets are discarded.

## CHAPTER THREE

Input “J” packets are passed to the Acutime (if mode 4 is enabled) exactly as they are input by the PC host processor. The packet data is not checked for structure, content or length. The Acutime will reject packets that are not structured properly. However, the Acutime will accept the data in any packet, which has the correct structure. No permanent damage can be done to the bc620AT or the Acutime by incorrect packet data or structure. It may take some detective work on the part of the user to recover from certain types of input errors. For example, if an elevation mask angle of 90° is entered, then the Acutime will not track any satellites because 90° is the maximum elevation angle. Errors of this type are not uncommon during software development.

**Note:** The bc620AT sets bit 2 of the ACK register (offset 0xB, Page 1) when a complete data packet is available in the output FIFO. The user can also elect to allow the bc620AT to generate an interrupt when a data packet is available.

## **CHAPTER FOUR**

---

### **ADDITIONAL bc620AT MODE FOUR CONSIDERATIONS**

#### **4.0 ADDITIONAL bc620AT MODE FOUR CONSIDERATIONS**

In addition to providing a gateway to the Acutime as described above the selection of bc620AT mode four produces the following changes to the bc620AT configuration:

- A GPS 1 PPS output is used as the timing reference for all bc620AT timing functions. The accuracy of this reference is typically +/- 1 microsecond.
- Input time code is ignored.
- Input 1 PPS pulses are ignored.
- The bc620 10MHz VCXO is disciplined to the corrected GPS 1 PPS output when satellites are being tracked.
- The Acutime does not have battery backed RAM. If the user elects to use GPS operating parameters other than the Bancomm selected default parameters, then these parameters must be downloaded via the appropriate packets.

#### **4.1 SELECTED DEFAULTS (LOADED BY bc620AT FIRMWARE AT BOOT)**

##### **4.1.1 PACKET 35H (I/O OPTIONS) 2, 2, 1, 0**

- (2) Latitude, Longitude, Altitude position format WGS-84 ellipsoid uses single precision Position and Velocity.
- (2) East, North, Up Velocity format.
- (1) UTC time tags selected Compute fixes ASAP Output time when computed.
- (0) Raw Measurement data off.

##### **4.1.2 PACKET 2CH (OPERATING PARAMETERS)**

Dynamics Code	4
Elevation Mask	10°
Signal Level Mask	6
PDOP Mask	12
PDOP Switch	8

This Page Intentionally Left Blank.

## **CHAPTER FIVE**

---

### **TRIMBLE STANDARD INTERFACE PROTOCOL**

#### **5.0 INTRODUCTION**

Depending how the system designer uses Trimble Standard Interface Protocol (TSIP) to configure the GPS receiver, final system performance can be optimized for any number of applications. For example, an aircraft or vessel operating with an unobstructed view of the sky, will most likely have different GPS operating requirements than vehicle operations in a downtown “urban canyon” environment, where frequent satellite blockages are the rule rather than the exception.

TSIP gives the system designer an unprecedented degree of freedom in choosing settings most appropriate to the task at hand. However, along with this flexibility comes the responsibility of making intelligent selections which are consistent with each other and the overall system objective.

The GPS receiver is provided with certain factory default settings, which will suffice for a great number of applications. For those requiring customization, application hints are provided for each packet, in the sections that follow. The key is to make judicious use of the powerful features TSIP has to offer the system designer. The system designer will greatly enhance overall system performance while reducing development time.

#### **5.1 INTERFACE SCOPE**

The Trimble Standard Interface Protocol is used in a large number of Trimble three and six channel board and navigation sensor designs. The protocol was originally defined for the Trimble Advanced Navigation Sensor (TANS) and is colloquially known as the TANS protocol even though applying to many other devices. References in this document to the TANS protocol should not be taken to apply to the TANS unit only, but to the whole range of Acutime sensors with the exception of those devices operating with an ASCII interface only. One important difference is that the RS-422 version has one bi-directional port only.

For the RS-232 Acutime range of sensors there are some particular considerations for the setup of Serial Channel A and Channel B (or Channels One and Two). Channel One operates in the same way as for all other Trimble two, three, and six satellite channel sensors, i.e. there is a series of automatic outputs described in the attached table. Do not confuse the number of satellite channels with the number of serial channels (or ports) - there is no relationship between the two. Reference is often made to serial channel or port interchangeably.

The second serial channel is “receive” only, i.e. it is intended normally for receipt of RTCM corrections. The default setting on start-up is 9600 baud, 8 bit, odd parity, and one stop bit.

## CHAPTER FIVE

This document describes in detail the format of the transmitted data, the packet identification codes, and all available information over the output channel to allow the user to choose the data required for his/her particular application. As will be discussed, the Acutime transmits some of the information (position and velocity solutions, etc.) automatically when it is available, while other information is transmitted only on request. Additional packets may be defined for particular products and these will be covered in the specifications for those products as necessary.

The bi-directional channel is the interface for command, control, and data output, for integration with control systems, vehicle tracking and management systems, navigation processors, displays, and other user equipment. The channel protocol is based on the transmission of packets of information between the user equipment and the unit. Each packet includes an identification code (1 byte, representing two hexadecimal digits) that identifies the meaning and format of the data that follows. Each packet begins and ends with ASCII control characters.

The TSIPPC utility, part of the GPS Software Toolkit, is designed to exercise many of the TSIP packets. The system integrator can use the utility to test the reaction of the sensor to these commands.

### 5.2 KEY ACUTIME SETUP PARAMETERS

Correct selection of the right operating parameters is a major factor in getting the best performance from the sensor. Packets 22 (set fix mode), 2C (set operating parameters), thirty-five (set I/O options), and packet 62 (set DGPS mode) are provided to change the receiver setup to the specific conditions of a particular user. The default values for the parameters in these packets are chosen to allow the receiver to operate well under the most varied and demanding conditions. A user may choose to change the default parameters if the receiver is only required to perform in a specific or limited environment. The user should be warned that when the receiver is exposed to operating conditions, which are different from the conditions described by the user setup, then the performance may be degraded. A brief description of the main parameters in these packets is given below so that a designer may understand the trade-off involved with a particular setup.

Initially the system designer needs to carefully consider the environment in which the receiver is expected to operate. There is a trade off between how frequently a position fix is output versus the absolute accuracy of the fix. The system designer needs to decide which takes priority and then make the appropriate selections. This becomes increasingly important when frequent satellite blockages are expected, as in downtown “urban canyon” environments and heavily foliated areas.

If one contrasts the sensor performance required for an aircraft flying level, or a marine vessel in a calm sea with that of a truck or bus being driven in an area of partial or complete blockage due to buildings and trees, then it is clear that different demands are being made on the sensor. Accuracy of the position fix is optimized when the “Synchronized Measurements” (Packet 35) option is ON. By so doing, the GPS will only output a position fix when it has continuous lock on three or more satellites simultaneously.

In a downtown urban canyon, however, it is difficult to maintain continuous lock on a given satellite constellation for any length of time. The sensor may find it almost impossible to pick up signals simultaneously from three or four satellites and will also be subject to continuous constellation shifts, since the satellites are frequently blocked from view by tall buildings. Other limitations are also set by the masks for PDOP, elevation and signal strength (SNR). Therefore, the system designer would be satisfied with a lower accuracy provided that fix density (or frequency) is at an acceptable level. Switching the “Synchronized Measurements” options to OFF gives the receiver more latitude in selecting and propagating old measurements to yield a position fix, albeit with less accuracy than one which maintained continuous lock.

The user can check for this condition occurring by setting the “Additional Fix Status” to ON. Packet 5E will identify the number of old measurements being used. Such data is most useful where the sensor is being used as part of a DR system. Checking the independence of measurements can be used as a weighting parameter in computing the overall solution from the combined sensor suite. “Minimize projection” is set ON by default. In this case where obscuration occurs, new positions will be computed for three to four seconds using the last velocity vector before obscuration occurred. This may not be desirable in combined sensor systems and should therefore be set to OFF.

One should also resist the temptation to set the elevation and SNR masks too low. The satellite geometry is sometimes improved considerably by selecting low elevation satellites. They are, however, subject to significant signal degradation by the greater ionospheric and tropospheric attenuation that occurs. They are also subject to more obscuration by the passing scenery when the sensor is in a moving vehicle. The code phase data from those satellites is therefore more difficult to decode and thus has more noise. If possible, the elevation mask should be set between five and ten degrees minimum.

The vehicle dynamics should also be correctly set so that the search algorithm for satellites operates in optimum fashion if there has been a complete loss of lock with the satellites due to short periods of obscuration. A more detailed discussion of the effects of the various parameters is set out on the next page.



### 5.2.1 FIX MODE

The preferable fix mode is 3-D, where altitude is calculated along with the latitude, longitude, and time. However, this requires four satellites with a PDOP below the PDOP mask set in packet 2C in order to obtain a position. Normally, this will provide the most accurate solution. Thus, if only 3-D solutions are desired, then the user should request 3-D manual mode. Depending on how the PDOP mask is set, this may be restrictive when the receiver is subjected to frequent obscuration, or when the geometry is poor due to an incomplete constellation.

Alternatively, if the user only wants a 2-D solution, then 2-D manual should be requested. In this case, the sensor uses either the last altitude obtained in a 3-D fix, or the altitude supplied by the user. However, any error in the assumed altitude will effect the accuracy of the latitude and longitude solution. High accuracy users should avoid this mode and should expect fixes with accuracy's that are at best as accurate as the supplied altitude. If a marine user enters sea-level as the altitude, then small errors in the horizontal solution will occur when the sea state is rough or there are high tidal variations. However, these errors may be smaller than the altitude errors induces by SA, so 2-D may be preferable for a marine user who does not want to observe "unusual" altitudes.

The default mode is AUTO 2-D/3-D, where the receiver first attempts to obtain a 3-D solution with a PDOP below both the PDOP mask and PDOP switch. If this is not possible, then the receiver attempts to obtain a 2-D solution with a PDOP less than the PDOP mask. This mode supplies fairly continuous position fixes even when there is frequent obscuration. This mode is preferable for most land or air applications, where altitude changes are occurring and there is occasional obscuration.

### 5.2.2 OPERATING PARAMETERS

These parameters are used to define the maximum dynamics the user expects to experience, and also to define the set of satellites which are usable based on the satellite geometry at the user's position.

#### 5.2.2.1 DYNAMICS CODE

The default is AIR mode, where the receiver assumes a high dynamic environment. In this case, the satellite search and reacquisition routines are optimized to tolerate high accelerations. A user which is subject to only benign accelerations (less than 1g) may benefit by selection of land or sea mode where the search and reacquisition routines assume a low acceleration environment. In this case, satellite loss-of-lock is due more often to obscuration rather than extreme dynamics.

### 5.2.2.2 ELEVATION MASK

This is the minimum elevation angle for satellites to be used in a solution output by the receiver. Satellites which are near the horizon are typically more difficult to track due to signal attenuation and are also generally less accurate due to higher variability in the ionospheric and tropospheric corruption of the signal. When there are no obstructions, the receiver can generally track a satellite down to near the horizon. However, when this mask is set to low, the receiver may experience frequent constellation switching due to low elevation satellites being obscured. Frequent constellation switching is undesirable because small position jumps may be experienced when SA is present and DGPS is not available to remove these effects. The benefit of a low elevation mask is that more satellites are available for use in a solution and a better PDOP may be yielded. The current mask is set to five degrees and provides a reasonable tradeoff of the benefits and drawbacks. High accuracy users may prefer a mask angle around ten degrees, where the ionosphere and troposphere begin to be more predictable.

### 5.2.2.3 SIGNAL LEVEL MASK

This mask defines the minimum signal strength for a satellite to be used in a solution. There is some internal hysteresis on this threshold which allows brief excursions below the threshold if lock is maintained and the signal was previously above the mask. The mask has been set to 4.0 in V1.14 and higher versions due to increased tracking capability now included. The mask should only be lowered cautiously since this mask is also used to minimize the effects of jammers on the receiver. High accuracy users may use a slightly higher mask of 5.0 - 6.0 since weaker measurements may be slightly noisier. However, good performance is available with the default setting.

### 5.2.2.4 PDOP MASK AND SWITCH

The PDOP mask is the maximum PDOP for which any 2-D or 3-D solution will be made. The switch is the level at which the receiver stops attempting a 3-D solution, and tries for a 2-D solution when in automatic 2-D, 3-D mode. The switch level has no affect on either manual mode. Raising the PDOP mask will generally increase the fix density during obscuration, but the fixes with the higher PDOP will be less accurate (especially with SA present). Lowering the mask will improve the average accuracy at the risk of lowering the fix density.

## 5.2.3 TIME OF FIX PARAMETERS

There are basically three options available for specifying the time of the GPS solution. When a satellite is in a normal continuous tracking mode, the time-of-applicability of the measurements is at 0.25 seconds and 0.75 seconds within each GPS second.

### 5.2.3.1 DEFAULT MODE

In the default mode, the time of solution is the time at which the GPS solution is computed. Thus, all measurements are projected by an interval which is roughly the amount of time it takes to compute the solution. The benefit of this approach is that the receiver provides a solution, which is applicable as close to the time of transmission as possible, which minimizes the burden on the user's computer. The drawback is that the measurement projection (which is exactly the same as dead reckoning with velocity) may induce some error during high accelerations.

### 5.2.3.2 INTEGER SECOND

In the integer second mode, the most recent measurements are projected to next integer second, and the solution is then valid at this time. The benefit of this mode is obviously the standard fix time. The drawbacks are that some measurement projection is performed and that the fix may be slightly older than with the default option.

### 5.2.3.3 MINIMIZED PROJECTION

In this mode, the time of solution is the time of the most recent measurements. Thus, if all measurements are taken at exactly the same time, then there is no measurement projection. If a selected satellite's measurement time is lagging the most recent measurement, then it is projected to this time. The only penalty is that the fix will be older than a fix provided with the above timing options. This is the best choice for users performing non real-time error analysis, or non real-time DGPS solution-space corrections. This is also the preferable mode for users integrating GPS with other sensors, where communication lags are the dominant latencies, and thus the time lag between the applicability and availability of the fix is small. This option is only available in version 1.14 and higher.

## 5.2.4 SYNCHRONIZED MEASUREMENTS

In this mode, all measurements are required to have the same time tag. This only applies to a six channel receiver, where selected satellites are tracked continuously on their own channel. If a satellite is lost which is in the selected set for the solution, then no fix will be made until a new selection is made. In the usual case (when the Synchronized measurement is off), slightly older measurements are tolerated (on the order of three to five seconds) in order to provide solutions when obscurations make it impossible to obtain exactly concurrent measurements from each satellite. The synchronized measurement mode combined with the minimized projection timing mode allows absolutely no measurement projection. This mode is ideal for vehicles, which experience high accelerations and want the highest accuracy. However, obscurations may reduce the fix density when there are limited satellites, so this mode should be used cautiously.

### 5.2.5 ADDITIONAL FIX STATUS

Setting bit 3 of the auxiliary byte in packet 35 will cause packet 5E to be output with each fix. Packet 5E has been added to give additional information about the fix concerning measurement latency. Packet 3E can be used to request packet 5E. These packets are in versions 1.14 and higher.

The least significant 3 bits of byte 1 of this packet contain the number of measurements used in the fix which were considered old. (Use of an old measurement will immediately cause a new satellite selection.) It turns out that some latency is desirable to “self-aid” the receiver, since a solution which has some projection error is probably good enough to help re-acquisition of lost satellites, and is probably better than no fix at all. These fixes are now flagged as containing old measurements with this packet.

The least significant 3 bits (Bits 0-2) of byte 0 of packet 5E contain the number of measurements used in the current solution that were also used in a previous solution. This gives an indication of how much independent information is contained in each fix. (NB for a three channel sequencing receiver, the channel allocation and fix rate may make it impossible for a new measurement to be taken from each satellite between fixes which are less than a second apart. Thus, it is possible to re-use a measurement in consecutive fixes even though the measurement is not considered old based on the current satellite distribution on sequencing channels). This information is useful when integrating the receiver with additional sensors. The fourth bit (Bit 3) of this byte flags fixes whether differential Doppler velocity was available.

The fifth bit (Bit 4) of byte 0 is used to flag fixes which are computed but are not output since the receiver is converging after being in an approximate position mode. In this case, the receiver says that it is doing fixes but no positions are being output. This condition is now flagged with this bit.

### 5.2.6 DGPS MODE

In manual DGPS mode, the receiver only computes solutions if corrections are available for the satellites, which are selected. This is the most accurate mode, but it is also the most selective, since the fix density is dependent on the availability of corrections. The auto mode avoids the fix density problem but opens the door to the possibility of going in and out of DGPS mode, which will cause position and velocity jumps. If accuracy is critical, one should stick with manual mode. On the other hand, if fix density is critical, auto DGPS is probably safer.

**CHAPTER FIVE**

In summary, the default parameter chosen allow the receiver to perform well in almost any environment. The user can optimize the receiver to a particular application if the vehicle dynamics and expected level of obscuration are understood. If the receiver is then taken out of this environment, then a specifically tuned receiver may not do as well operating a receiver with the default options. Table One shows some possible parameter selections as a function of the dynamics, obscuration, and whether accuracy or fix density is important.

NA = Not Applicable

DC = Don't Care (In other words, it could be set either way.)

**Table One**  
**Suggested Parameter Settings**

<b>Parameter</b>	<b>High Obscuration</b>		<b>Low Obscuration</b>	
	<b>Accuracy</b>	<b>Fixes</b>	<b>Accuracy</b>	<b>Fixes</b>
<b>Fix Mode</b>	man 3D	Auto	man3D	Auto
<b>Elevation Mask</b>	10	5	10	5
<b>Signal Mask</b>	6.0	4.0	6.0	4.0
<b>PDOP Mask</b>	6.0	12.0	6.0	12.0
<b>PDOP Switch</b>	N/A	8.0	N/A	8.0
<b>Timing Mode</b>	min proj	DC	min proj	DC
<b>Sync Meas.</b>	OFF	OFF	ON	ON
<b>Min. Projection</b>	ON	DC	ON	DC
<b>DGPS Mode</b>	man ON	DC	man ON	DC

## CHAPTER SIX

---

### APPLICABLE DOCUMENTS

#### 6.0 APPLICABLE DOCUMENTS

Unless otherwise indicated, the issue of each document, which was in effect on 1 May 1987, is the issue to be used.

SS-GPS-300B	System Specification for the NAVSTAR Global Positioning System
ICD-GPS-200	NAVSTAR GPS Space Segment/Navigation User Interfaces
17035	Trimble Advanced Navigation Sensor, Specification and User's Manual, Rev. A, October 1990
RTCM (SC-104)	RTCM Recommended Standards For Differential NAVSTAR GPS Service, Version 2.0. RTCM Special Committee No.104. Published by the Radio Technical Commission For Maritime Services, Washington, D.C. January 1, 1990.

GPS - A Guide to the Next Utility - Trimble 1990 - an introduction in non-mathematical terms to the GPS system.

Proceedings - Institute of Navigation Washington DC - A series of three abstracts published between 1980 and 1986 of papers from the Journal of the Institute of Navigation. Essential source material for any system designer.

This Page Intentionally Left Blank.

## CHAPTER SEVEN

---

### SIGNAL CHARACTERISTICS

#### 7.0 SIGNAL CHARACTERISTICS

##### 7.1 GENERAL

The user interface signals are EIA RS-422 balanced conductor pairs. For the short line lengths anticipated, the user's receive-end need not be terminated. The format is standard serial, sent least-significant-bit first, at 9,600 baud, with 8 data bits, odd parity, and 1 stop-bit. "Clear to send" flow control signals are included in the design and should be used to eliminate the possibility of over-run.

TSIP will also operate with RS-232 configurations.

**Note:** Several packets have significant effects on the operation of the Acutime sensor where an external battery back-up is used for the internal memory. These are noted in the text and the system designer should be aware of these effects in the structure of the software.

##### 7.2 PACKET DATA FORMAT

Each packet type is described below. Where necessary, specific data formats are given.

The INTEGER data type is a 16 bit signed number sent in twos complement format, most significant byte first.

A floating point number, sometimes called "scientific notation" (for decimal numbers), or a REAL number, consists of a signed mantissa and a signed exponent. The precision is determined by the number of digits in the mantissa, and the range of expressible values is determined by the number of digits in the exponent. In a *non-zero binary* floating-point number, the mantissa consists of a "one," followed by the binary point, followed by the fractional part of the mantissa. The leading binary "one" is redundant.

For floating-point numbers, the Acutime uses the ANSI/IEEE Std 754 IEEE Standard for Binary Floating-Point Arithmetic, in which the formatted exponent is biased to avoid the use of an exponent sign, the mantissa's redundant leading "one" is omitted, and various special cases are specified. The IEEE 754 standard specifies two degrees of precision, "SINGLE" and "DOUBLE," both of which are used in the Acutime. The *double* precision format uses more bits both in the mantissa (for greater precision) and in the exponent (for greater range). The IEEE 754 format is described briefly below.

The sign-bit is one for a negative number and is zero for a positive number.



## CHAPTER SEVEN

To ensure that the formatted exponent is non-negative, and thus to avoid the use of an exponent sign, the formatted exponent (the biased exponent) is the sum of the actual (signed, unbiased) exponent plus a constant (the bias).

The redundant leading “one” is not included. Only the fractional part of the mantissa is included and is called the “fraction.”

The value zero is formatted by setting both the biased exponent and the fraction to zero. This special case must be recognized as zero and not interpreted as described above for a non-zero number.

The IEEE 754 standard specifies various other special cases. For programming and for detailed data analysis, the user should consult the IEEE standard.

The Acutime “SINGLE” data type is a 32-bit (4 byte) single-precision floating-point number in the ANSI/IEEE Std 754 SINGLE (short) format. The first byte sent contains the sign-bit of the mantissa and the 7 most-significant bits of the biased exponent. The second byte contains the least-significant bit of the biased exponent, followed by the 7 most-significant bits of the fraction (the part of the mantissa to the right of the binary point). The remaining 2 bytes complete the fraction. The exponent bias is +127; i.e., the biased exponent is the actual exponent +127. With the implied (unformatted) leading “one,” the single-precision mantissa contains 24 significant bits.

The Acutime “DOUBLE” data type is a 64-bit (8 byte) double-precision floating-point number in the ANSI/IEEE Std 754 DOUBLE (long) format. The first byte sent contains the sign-bit of the mantissa and the 7 most-significant bits of the biased exponent. The second byte contains the 4 least-significant bits of the biased exponent, followed by the 4 most-significant bits of the fraction. The remaining 6 bytes complete the fraction. The exponent bias is +1,023. With the implied (not formatted) leading “one,” the double-precision mantissa contains 52 significant bits.

### 7.3 PACKET STRUCTURE

In both directions of information transmission, the data format conforms to a packet structure as follows. Each packet starts with the two-character sequence.

- <DLE>      The ASCII “data link escape” character, 1 byte, value 10 hex.
  
- <id>        The packet type identification number, 1 byte, expressed as 2 hexadecimal digits. This byte can have any value other than 10 hex (ASCII <DLE>) or 03 hex (ASCII <ETX>). The values and their meanings are given in the remainder of this chapter. Each packet ends with the two-character sequence.

- <DLE>        The ASCII “data link escape” character, 1 byte, value 10 hex.
- <ETX>        The ASCII “end-of-text” character, 1 byte, value 03 hex.

The packet format is shown below:

<DLE> <id> ... data bytes ... <DLE> <ETX>

Each packet data byte can have any 8 bit value, with the one requirement that any data byte of value 10 hex (<DLE>) must be sent twice. The receiving devices (in both the Acutime and the user’s data terminal) must compress all occurrences of two <DLE> characters into one <DLE> data byte. The data portion of the packet may be from 0 to 255 bytes long, not counting <DLE> stuffing.

### 7.3.1 PACKETS SENT BY THE USER TO ACUTIME

The table below provides the packet ID numbers sent by the user to Acutime, a short description of each packet, and the identities of the packets, which Acutime sends in response. In some cases, the response packets depend on user-selected options. These selections are covered in the packet descriptions below. Details are provided for each packet type in the following sections. Descriptions of some packets assume availability of battery-backed memory. The battery has to be provided externally through pin five if required.

Table One

<id> (hex)	Description	Response Packet Sent By Acutime
1D	Clear Oscillator Offset	--
1E	Clear Battery Back-up then Reset	--
1F	Request Software Versions	45
20	Request Almanac	40
21	Request Current Time	41
22	Mode Select (2-D, 3-D, Auto)	--
23	Initial Position (XYZ ECEF)	--
24	Request Acutime Position Fix Mode	44 or 6D
25	Initiate Soft Reset and Self Test (Equivalent to Cycling Power)	45, 46, 4B, 42 or 83, 4A or 84
26	Request Health	46, 4B
27	Request Signal Levels	47
28	Request GPS System Message	48
29	Request Almanac Health Page	49
2A	Altitude for 2-D Mode	--
2B	Initial Position (Latitude, Longitude, Altitude)	--
2C	Set/Request Operating Parameters	4C
2D	Request Oscillator Offset	4D
2E	Set GPS Time	4E
31	Accurate Initial Position (XYZ Cartesian ECEF)	--
32	Accurate Initial Position (Latitude, Longitude, Altitude)	
34	Satellite Number for Single Satellite Mode	--
35	Set/Request I/O Options	55
36	Velocity Aiding of Acquisition	--
37	Request Status and Values of Last Possible and Velocity	57; 42 or 83 or 4A or 84; 43 or 56
38	Request/Load Satellite System Data	58
39	Set/Request Satellite Disable or Ignore Health	59
3A	Request Last Raw Measurement	5A
3B	Request Satellite Ephemeris Status	5B
3C	Request Tracking Status	5C
3D	Configure Channel A for RTCM (SC-104) Differential GPS	3D
3E	Request Additional Fix Parameters	5D
62	Set/Request Differential GPS Position Fix Mode	82
65	Request Differential Correction Status	85
75	Set/Request Best 4/High 6/Smart-8 Mode	76

### 7.3.1.1 1D CLEAR OSCILLATOR OFFSET

This packet commands the Acutime to clear the oscillator offset stored in battery-backed memory. This packet contains 1 data byte equal to the ASCII letter “C,” 43 hex. Packet 2D hex can be used to request the current value of the offset. This information is used mainly for service. In normal use, there is no need to send this packet.

### 7.3.1.2 1E CLEAR BATTERY BACK-UP, THEN RESET

This packet commands the Acutime to clear all battery back-up data and to perform software reset. This packet contains 1 data byte equal to the ASCII letter “K,” 4B hex.

\* \* \* CAUTION \* \* \*

All almanac, ephemeris, current position, mode, and calibration information is lost by the execution of this command. In normal use, this packet should not be sent.

### 7.3.1.3 1F REQUEST SOFTWARE VERSIONS

This packet requests information about the version of software running in the Navigation and Signal Processors. This packet contains no data bytes. The Acutime returns packet 45 hex.

### 7.3.1.4 20 REQUEST ALMANAC

This packet requests almanac data for one satellite from the Acutime. This packet contains 1 data byte specifying the satellite PRN number. The Acutime returns packet 40 hex.

### 7.3.1.5 21 REQUEST CURRENT TIME

This packet requests current GPS time. This packet contains no data. The Acutime returns packet 41 hex.

**7.3.1.6 22 POSITION FIX MODE SELECT**

This packet commands the Acutime to operate in a specific position fix mode. This packet contains 1 data byte indicating the mode, as follows:

Mode	Data Byte Value	PKTNON Key Command
Automatic	0 (Default Value)	^N
One Satellite (0-D)	1	^T
Three Satellite (2-D)	3	n
Four Satellite (3-D)	4	N

This selection is held in battery-backed memory

The one satellite (0-D) mode uses a single satellite to determine receiver clock error (time) and error rate (frequency) when the position is known precisely. In this mode, the Acutime computes no positions or velocities. Instead, the Acutime sends packet 54 hex with the clock bias and bias rate. This can be used for time transfer applications and to enable the Acutime to maintain the accuracy of the 1pps (Pulse Per Second) output even if a full position fix cannot be done.

**7.3.1.7 23 INITIAL POSITION (XYZ CARTESIAN ECEF)**

This packet provides the Acutime with an approximate initial position in Cartesian ECEF (Earth Centered, Earth Fixed) WGS-84 coordinates. This packet causes a worldwide search for the user’s position, starting at the position entered via this packet. That takes about six to ten seconds before the Acutime can provide more fixes. This packet is useful if the user has moved more than about 1,000 miles after the previous fix. (The Acutime can initialize itself without any data from the user. This packet merely reduces the time required for initialization.) This packet does not cause software reset.

The data format is shown below:

The X-axis points toward the intersection of the equator and the Greenwich meridian, the Y-axis points toward the intersection of the equator and the 90° meridian, and the Z-axis points toward the North Pole.

Byte #	Item	Type	Units
0-3	X	SINGLE	Meters
4-7	Y	SINGLE	Meters
8-11	Z	SINGLE	Meters

**7.3.1.8 24 REQUEST ACUTIME POSITION FIX MODE**

This packet requests current position fix mode of the Acutime. This packet contains no data. The Acutime returns packet 44 hex or 6D hex.

**7.3.1.9 25 INITIATE SOFT RESET AND SELF TEST**

This packet commands the Acutime to perform software reset. This is equivalent to cycling the power. The Acutime performs a self-test as part of the reset operation. This packet contains no data. The Acutime returns packets 41, 45, 46, 4B, (42 and 4A) or (83 and 84), all hex. The Acutime sends packet 45 hex only on power-up and reset (or on request). Thus if packet 45 appears not requested, then either the Acutime power was cycled or the Acutime was reset.

**7.3.1.10 26 REQUEST HEALTH**

This packet requests health and status information from the Acutime. This packet contains no data. The Acutime returns packet 46 hex and 4B hex.

**7.3.1.11 27 REQUEST SIGNAL LEVELS**

This packet requests signal levels for all satellites currently being tracked. This packet contains no data. The Acutime returns packet 47 hex.

**7.3.1.12 28 REQUEST GPS SYSTEM MESSAGE**

This packet requests the GPS system ASCII message sent with the navigation data by each satellite. This packet contains no data. The Acutime returns packet 48 hex.

**7.3.1.13 29 REQUEST ALMANAC HEALTH PAGE**

This packet requests the Acutime to send the health page from the almanac. This packet contains no data. The Acutime returns packet 49 hex.

**7.3.1.14 2A ALTITUDE FOR 2-D MODE**

This packet provides the altitude to be used for manual two-dimensional (three-satellite) mode. This altitude is used for Auto 2-D mode until a 3-D fix is performed. This packet contains one SINGLE number (4 bytes) specifying the altitude in meters, using the WGS-84 model of the earth or MSL geoid altitude depending on I/O options (set by packet 35). This altitude value is held in battery-backed memory.

**7.3.1.15 2B INITIAL POSITION (LATITUDE, LONGITUDE, ALTITUDE)**

This packet provides the Acutime with an approximate initial position in latitude and longitude coordinates (WGS-84). This packet causes a worldwide search for the user's position, starting at the position entered via this packet. That takes about six to ten seconds before the Acutime can provide more fixes. This packet is useful if the user has moved more than about 1,000 miles after the previous fix. (The Acutime can initialize itself without any data from the user. It merely requires more time.) This packet does not cause software reset.

The data format is shown below:

Byte #	Item	Type	Units
0-3	Latitude	SINGLE	Radians, North
4-7	Longitude	SINGLE	Radians, East
8-11	Altitude	SINGLE	Meters

**7.3.1.16 2C SET/REQUEST OPERATING PARAMETERS**

This packet optionally sets the operating parameters of the Acutime receiver and requests the current values after setting them. The data format is shown below. The Acutime returns packet 4C hex.

The dynamics code indicates the expected vehicle dynamics and is used to assist the initial solution.

The elevation angle mask determines the lowest angle at which the Acutime tries to track a satellite.

The signal level mask sets the required signal level for a satellite to be used for position fixes.

The PDOP mask sets the maximum PDOP with which position fixes are calculated. The PDOP switch selects the 2-D and 3-D mode. If four or more satellites are available and the resulting PDOP is not greater than the PDOP switch value, then three-dimensional fixes are calculated. The PDOP switch is effective only in the automatic 2-D/3-D mode.

Byte Number	Item	Type	Units	Default Value
0	Dynamics Code	BYTE		3 (See Table)
<b>Value</b>		<b>Meaning</b>		<b>Assumed Velocity</b>
0		Current Value is Left Unchanged		
1		Land		< 120 Knots
2		Sea		< 50 Knots
3		Air (Difficult)		< 800 Knots
4		Static		Stationary
1-4	Elevation Angle Mask	SINGLE	Radians	0.1745 (10°)
5-8	Signal Level Mask	SINGLE	---	6
9-12	PDOP Mask	SINGLE	---	12
13-16	PDOP Switch (3-D or 2-D)	SINGLE	---	8

A negative value in a SINGLE field leaves that current setting unchanged.

This information is held in memory.

Mode 4 selection informs the Acutime that it is stationary. Any position fix computed or provided via the data channels is assumed to be accurate indefinitely. When the dynamics code is set to static (byte value = 4) and the fix mode is automatic (set by packet 22 hex), then the Acutime enters automatic one satellite mode when a position fix cannot be performed but there is at least one usable satellite. In this mode, no positions or velocities are computed. Instead, the Acutime sends packet 54 hex with the clock bias and bias rate. As long as the Acutime is truly stationary, this mode can be used for time transfer applications and to enable the Acutime to maintain the accuracy of the 1pps (Pulse Per Second) output even if a full position fix cannot be done.

### 7.3.1.17 2D REQUEST OSCILLATOR OFFSET

This packet requests the calculated offset of the Acutime master oscillator and contains no data. The Acutime returns packet 4D hex. This packet is used mainly for service. The permissible oscillator offset varies with the particular Acutime unit.



**7.3.1.18 2E SET GPS TIME**

This packet provides the approximate GPS time of week and the week number to the Acutime. The Acutime returns packet 4E hex. The data format is shown on the following page. The GPS week number reference is Week # 0 starting January 6, 1980. The seconds count begins at the midnight, which begins each Sunday morning.

Byte Number	Item	Type	Units
0-3	GPS Time of Week	SINGLE	Seconds
4-5	GPS Week Number	INTEGER	Weeks

This packet normally is not needed as the internal battery-powered clock keeps time to sufficient accuracy for finding position rapidly.

**7.3.1.19 31 ACCURATE INITIAL POSITION (XYZ CARTESIAN ECEF)**

This packet is identical in content to packet 23 hex. This packet provides an initial position to the Acutime in XYZ coordinates. However, the Acutime assumes the position provided in this packet to be accurate. This packet is used for satellite acquisition aiding in systems where another source of position is available and in time transfer (one-satellite mode) applications. For acquisition aiding, the position provided by the user to the Acutime in this packet should be accurate to a few kilometers. For high-accuracy time transfer, position should be accurate to a few meters.

**7.3.1.20 32 ACCURATE INITIAL POSITION (LATITUDE, LONGITUDE, ALTITUDE)**

This packet is identical in content to packet 2B hex. This packet provides the Acutime with an approximate initial position in latitude, longitude, and altitude coordinates. However, the Acutime assumes the position provided in this packet to be accurate. This packet is used for satellite acquisition aiding in systems where another source of position is available and in time transfer (one-satellite mode) applications. For acquisition aiding, the position provided by the user to the Acutime in this packet should be accurate to a few kilometers. For high-accuracy time transfer, position should be accurate to a few meters.

**7.3.1.21 33 REQUEST A-TO-D READINGS**

Since the Acutime does not have an internal A-to-D chip, this function is not supported.

**7.3.1.22 34 SATELLITE NUMBER FOR ONE-SATELLITE MODE**

This packet allows the user to control the choice of the satellite to be used for the one-satellite mode. This packet contains 1 byte. If the byte value is 0, the Acutime chooses the usable satellite with the highest elevation above the horizon. This automatic selection of the highest satellite is the default action, and the Acutime does this unless it receives this packet. If the byte

value is from 1 to 32, the packet specifies the PRN number of the satellite to be used. This selection is not kept in battery-backed memory.

**7.3.1.23 35 SET/REQUEST I/O OPTIONS**

This packet requests the current I/O option states and optionally allows the I/O option states to be set as desired. To request the option states without changing them, the user sends only the packet “<DLE> (35 hex) <DLE> <ETX>” with no data bytes included. To change any option states, the user includes 4 data bytes with the values indicated below in the packet. The I/O options, their default states, and the byte values for all possible states are shown below. A glossary is given at the end of the table. These option states are held in battery-backed memory. The Acutime returns packet 55 hex.

Byte Number	Parameter Name	Bit Position	Default Bit Value	Option	Associated Packet
0	Position	0 (LSB)	1	XYZ ECEF Output 0: off 1: on	42 or 83
		1	0	LLA Output 0: off 1: on	4A or 84
		2	0	LLA ALT Output 0: HAE WGS-84 1: MSL Geoid	4A or 84 or 8F-01 or 8F-02
		3	0	ALT Input 0: HAE WGS-84 1: MAL Geoid	2A
		4	0	Precision-of-Position Output 0: Send Singe-Precision Packet 42 and/or 4A. 1: Send Double-Precision Packet 83 and/or 84.	
		5	0	Super Packet Output 0: off 1: on	
		6	0	Super Packet Format 0: Binary 1: ASCII	
		7	0	Unused	

CHAPTER SEVEN

**Note:** If bit 5 is 0 then no super packets are output. If bit 5 and 6 are 1 then packet 8E-01 is output. If bit 5 is 1 and 6 is 0 then packet 8F-02 is. If super packet output is selected then 8F-01 or 8F-02 packets are output instead of the standard 4A or 84 packets.

Byte Number	Parameter Name	Bit Position	Default Bit Value	Option	Associated Packet
1	Velocity	0	1	XYZ ECEF Output 0: off 1: on	43
		1	0	ENU Output 0: off 1: on	56
		2-7	Unused		
2	Timing	0	0	Time Type 0: GPS Time 1: UTC	
		1	0	Fix Computation Time 0: ASAP 1: Next Integer Sec	
		2	0	Output Time 0: When Computed 1: Only on Request	37
		3	0	Synchronized Measurements 0: Off 2: On	
		4	0	Minimize Projection (V1.14 Onwards)	
		5-7	0	Unused	

Byte Number	Parameter Name	Bit Position	Default Bit Value	Option	Associated Packet
3	Auxiliary	0	0	Raw Measurements 0: Off 1: On	5A
		1	0	Doppler Smoothed Code Phase (V1.12 Onwards) 0: Off 1: On	
		2	0	Additional Fix Status (V1.14 Onwards) 0: Off 1: On	5E
		3-7	Unused		

Glossary for the table on the previous page:

**ALT**

Altitude.

**ECEF**

Earth-Centered, Earth-Fixed.

**XYZ**

Cartesian Coordinates.

**LLA**

Latitude, Longitude, Altitude.

**HAE**

Height Above Ellipsoid.

**WGS-84**

Earth Model (Ellipsoid).

**MSL Geoid**

Earth (Mean Sea Level) Mode.

**UTC**

Coordinated Universal Time.

**7.3.1.24 36 VELOCITY AIDING OF ACQUISITION**

In this packet the user provides velocity information to the Acutime from an external source to aid in satellite acquisition and reacquisition.

Byte	Item	Type	Units
0	Coordinate Select	BYTE	
<b>Byte Value</b>	<b>Meaning</b>		
0	XYZ		
1	ENU (East, North, Up)		
1	Velocity Aiding Enable Flag	BYTE	
<b>Byte Value</b>	<b>Meaning</b>		
0	Disable Velocity Aiding		
1	Enable Velocity Aiding (See Note Below)		
<b>Byte Value</b>	<b>Meaning</b>		
2-5	X or East Velocity	SINGLE	meters/second
6-9	Y or North Velocity	SINGLE	meters/second
10-13	X or Up Velocity	SINGLE	meters/second

If the velocity aiding enable flag is set to “one,” the Acutime assumes that the velocity data is accurate to twenty-five meters per second or better and that it can be used for aiding. The Acutime continues to use this data until another packet 36 hex is sent with the aiding enable flag set to “zero” (to disable velocity aiding). Once aiding has begun, the Acutime must be informed (via a new packet 36) of any velocity changes greater than twenty-five meters per second until velocity aiding is disabled. Once acquisition occurs, the aiding data is ignored, but if acquisition later is lost, then the aiding data is used again.

### 7.3.1.25 37 REQUEST STATUS AND VALUES OF LAST POSITION AND VELOCITY

This packet requests information regarding the source codes, time of last fix, and GPS week and UTC offset. The Acutime returns packet 57 and the appropriate position packet 42 or 4A, or 83 or 84, and the appropriate velocity packet 43 or 56, based on the I/O options in effect.

### 7.3.1.26 38 REQUEST/LOAD SATELLITE SYSTEM DATA

This packet is not supported by the GPS Software Toolkit - PKTMON. This packet requests current satellite data (almanac, ephemeris, etc.) or permits loading initialization data from an external source (for example, by extracting initialization data from an operating Acutime unit via a data logger or computer and then using that data to initialize a second Acutime unit). The Acutime returns packet 58.

**Note:** The Acutime can initialize itself without any data from the user. It merely requires more time.)

To request data without loading data, use only bytes 0 through 2; to load data, use all bytes. Before loading data, observe the caution notice below.

Byte Number	Item	Type	Byte Value	Meaning
0	Operation	BYTE	1	Request Data From Acutime
			2	Load Data Into Acutime
1	Type of Data	BYTE	1	Not Used
			2	Almanac
			3	Health Page, T_oa, WN_oa
			4	Ionosphere
			5	UTC
			6	Ephemeris
2	Sat PRN #	BYTE	0	Data That is Not Satellite ID Specific
			1 to 32	Satellite PRN Number
3	Length (n)		BYTE	Number of Bytes of Data to be Loaded
4 to n+3	Data		n BYTES	

\* \* \* CAUTION \* \* \*

Proper structure of satellite data is critical to Acutime operation. Data format, content, and protocol should be obtained through consultation with Trimble Navigation before using this feature.

Improper data can cause the Acutime software to lock up immediately after tun on, so that any battery-backed memory cannot be cleared except by removing the battery backup voltage. (The Acutime is not damaged physically by improper data, but it may be unusable until it is serviced.) *Requesting* data is *not* hazardous. *Loading* data improperly *is* hazardous. Use this packet only with extreme caution.

**7.3.1.27 39 SET/REQUEST SATELLITE DISABLE OR IGNORE HEALTH**

Normally the Acutime selects satellites for use in GPS solution according to whether the candidate satellites are in good health and whether they satisfy the mask values for elevation angle, signal level, and PDOP. This packet allows the user to tell the Acutime either to disable unconditionally the selection of any particular satellite or to ignore the health of any particular satellite that otherwise is acceptable for selection. The Acutime returns packet 59.

## CHAPTER SEVEN

It should be noted that when viewing the satellite disabled list, the satellites are not numbered but are in numerical order. The disabled satellites are signified by a one and enabled satellites are signified by a zero.

Byte Number	Item	Type	Byte Value	Meaning
0	Operation	BYTE	1	Enable for Selection (Default)
			2	Disable for Selection
			3	Request Enable or Disable Status of All Thirty-two Satellites.
			4	Heed Health on Satellite (Default)
			5	Ignore Health on Satellite
			6	Request Heed or Ignore Status on All Thirty-two Satellites.
1	Satellite #	BYTE	0	All Thirty-two Satellites
			1 to 32	Any One Satellite PRN Number

This information is *not* held in battery-backed memory. At power-on and after a reset the default values are set for all satellites.

**\* \* \* CAUTION \* \* \***

Ignoring health can cause the Acutime software to lock up, as an unhealthy satellite may contain defective data. Generally, such software lock-up is cleared by the Acutime user, although improper data can cause the Acutime software to lock up immediately after turn-on, so that the battery backed memory cannot be cleared except by instrument service. (The Acutime is not damaged physically by this, but it may be unusable until it is serviced.) Use extreme caution in ignoring satellite health.

### 7.3.1.28 3A REQUEST LAST RAW MEASUREMENT

This packet requests the most recent raw measurement data for one specified satellite. The Acutime returns packet 5A hex.

Byte Number	Item	Type	Byte Value	Meaning
0	Satellite #	BYTE	0	All Satellites in the Current Tracking Set
			1-32	Desired Satellite

**7.3.1.29 3B REQUEST CURRENT STATUS OF SATELLITE EPHEMERIS DATA**

This packet requests the current status of satellite ephemeris data. The Acutime returns packet 5B hex.

Byte Number	Item	Type	Byte Value	Meaning
0	Satellite #	BYTE	0	All Satellites in the Current Tracking Set
			1-32	Desired Satellite

**7.3.1.30 3C REQUEST CURRENT SATELLITE TRACKING STATUS**

This packet requests the current satellite tracking status. The Acutime returns packet 5C hex.

Byte Number	Item	Type	Byte Value	Meaning
0	Satellite #	BYTE	0	All Satellites in the Current Tracking Set
			1-32	Desired Satellite

**7.3.1.31 3D REQUEST OR SET DATA CHANNEL A CONFIGURATION FOR DIFFERENTIAL CORRECTIONS**

This packet requests, and optionally sets, the data Channel A configuration for differential corrections. This configuration includes the baud rate, number of bits, parity, and number of stop bits for channel A and also the language mode. When this packet is used only to request the configuration the packet contains no data bytes. When this packet is used to set the configuration, the packet contains the data bytes shown on the following page.

The language mode is defined as follows. For transmission, the language mode specifies whether packets are output on Channel A. For reception, the language mode specifies whether packets or RTCM data are received on channel A (1).

The baud rate for the transmitter and the receiver can be set independently. The number of bits, parity, and the stop bits are common between them. The default mode is packets for both transmission and reception at 9,600 baud with 8 data bits, odd parity, and 1 stop bit.

When the language mode for reception is set to RTCM (SC-104), raw RTCM (SC-104) data is accepted on channel A for differential GPS corrections. These corrections are used only if the GPD mode is set to manual GPS or automatic with packet 62.



## CHAPTER SEVEN

When an Acutime receives a packet 3D with no data bytes, it responds with packet 3D with current settings.

**Note:** The default of byte 5 is set to RTCM automatically on start-up, with default settings for the port at 9600, eight, zero, and one.

Byte	Item	Type	Units			
0	XMT Baud Rate Code	BYTE	0: 50	8: 2400	1: 110	9: 4800
			4: 300	11: 9600	5: 600	12: 38.4K
			6: 1200	28: 19.2K		
1	RVC Baud Rate Code	BYTE	0: 50	8: 2400	1: 110	9: 4800
			4: 300	11: 9600	5: 600	12: 38.4K
			6: 1200	28: 19.2K		
2	Parity and #bits/Char Code	BYTE	xxxpppbppp:	0: Even Parity		
				1: Odd Parity		
				4: No Parity		
			bb:	2: 7		
				3: 8		
3	Stop Bits Code	BYTE	7: 1 Stop Bit			
			15: 2 Stop Bits			
4	Language Mode for Transmission	BYTE	0: Packets			
			1: Off			
			5: NMEA			
5	Language Mode for Reception	BYTE	0: Packets			
			1: RTCM (SC-104)			

**Note (1):** In most RS-232 versions of the sensor, RTCM input for the second channel is the default mode at power-on to allow for direct connection to a radio modem. The default speed is 9600, eight, zero, one.

**Note (2):** If the bit is set to 5, then output is standard NMEA ASCII, GGA + VTG.

This information is held in battery backed memory. After loss of battery backed memory, the default values are set.

**7.3.1.32 3E REQUEST ADDITIONAL FIX PARAMETERS**

This packet is sent to request the attributes of a position fix, i.e. the number of old measurements used in the fix, whether differential Doppler velocity is available, and whether the fix has converged. The response is Packet 5E. Packet 35 can be set to request packet 5E automatically.

**7.3.1.33 62 REQUEST/SET DIFFERENTIAL POSITION FIX MODE**

This packet requests and optionally sets the differential position fix mode of the Acutime. When this packet is used to request the mode the packet contains no data bytes. When this packet is used to set the mode the packet contains only 1 data byte to specify the mode. In response, the Acutime always sends packet 82, which contains the current mode.

The following modes can be set:

0	Manual GPS (Differential Off) (Default)
1	Manual GPD (Differential On)
2 or 3	Automatic

“Manual GPS” (mode 0) sets the Acutime to do position solutions without differential corrections, even if the differential corrections are available.

“Manual GPD” (mode 1) sets the Acutime to do position solutions only if valid differential correction data are available.

“Automatic” (data byte value = either 2 or 3), the Acutime automatically sets itself to mode 2 (differential currently off) if the Acutime is not receiving differential correction data for all satellites in a constellation which meets all other masks. It automatically sets itself to mode 3 (differential currently on) if it is receiving differential correction data for all satellites in a constellation, which meets all other masks. Packet 82, which the Acutime sends in response to receiving packet 62, indicates whether the Acutime currently is in mode 2 or 3.

An attempt to set a mode outside this set results in simply requesting packet 82.

The selected mode (manual GPS, manual GPD, or automatic) is held in battery-backed memory.

**7.3.1.34 65 REQUEST DIFFERENTIAL CORRECTION STATUS**

This packet requests the status of differential corrections for a specific satellite or for all satellites for which data is available. This packet contains only 1 byte specifying the PRN number of the desired satellite or zero to request all available. The response is a packet 85 for each satellite.

### 7.3.1.35 75 SET/REQUEST BEST 4/HIGH 6/SMART 8-MODE

This packet sets the constellation mode of the Acutime. The Acutime returns packet 76. In “High 6” mode, the receiver will attempt to track the six highest elevation satellites as determined by the almanac, and will use up to six satellites in an over-determined solution.

In “Best 4” mode, the Acutime chooses four satellites with the best geometry for a position fix and tracks the other four. In case one of the best four satellites is temporarily masked, one of the other four can be swapped in immediately to provide a position fix.

“Smart 8” is a sequencing mode, which tracks the highest eight satellites and uses up to eight satellites in an over-determined solution.

To simply request the mode, the packet is sent with no data bytes.

To set the mode, a single data byte is sent. The data byte can have one of the three values:

- 0 = Best 4 Mode
- 1 = High 6 (Over Determined) Mode (Default Mode for the Acutime)
- 2 = Smart 8 (Over Determined Smart Sequencing) Mode

### 7.3.2 PACKETS SENT BY ACUTIME TO THE USER

The table next page provides the packet ID numbers sent by the Acutime to the user, a short description of each packet, and an indication of when the packet is sent. Details are provided for each packet type in the following sections.

**SIGNAL CHARACTERISTICS**

<b>Id (Hex)</b>	<b>Description</b>	<b>When Sent</b>			<b>Response to Packet Number</b>
		<b>Power Up</b>	<b>Automatic</b>	<b>If Selected</b>	
40	Almanac Data for Specified Sat		X		20
41	GPS Time	X (1)	X (1)		21
42	Single-Precision XYZ Position	X (2)		X	25, 37
43	Velocity Fix (XYZ ECEF)			X	37
44	Satellite Selection, PDOP, Mode			X	24
45	Software Version Information	X			1F, 25
46	Health of Acutime		X	X	25, 26
47	Signal Level for all Satellites				27
48	GPS System Message				28
49	Almanac Health Page for all Sats			X	29
4A	Single-Precision LLA Position	X (2)		X	25, 37
4B	Machine Code/Status	X	X		25, 26
4C	Report Operating Parameters				2C
4D	Oscillator Offset			X	2D
4E	Response to Set GPS Time				2E
54	One Satellite Bias and Bias Rate		X		22
55	I/O Options				35
56	Velocity Fix (ENU)			X	37
57	Information About Last Computed Fix				37
58	GPS System Data/Acknowledge				38
59	Sat Enable/Disable and Health Heed				39
5A	Raw Measurement Data		X		3A
5B	Satellite Ephemeris Status		X		3B
5C	Satellite Tracking Status				3C
5E	Additional Fix Status			X	3E, 35
5F	Severe Failure Report		X		
6D	All-In-View Satellite Selection				24
76	Best 4/High 6/Smart 8 Mode				75
82	Differential Position Fix Mode				62
83	Double-Precision XYZ Position	X (2)		X	25, 37
84	Double-Precision LLA Position	X (2)		X	25, 37
85	Differential Correction Status				65

## CHAPTER SEVEN

**Note (1):** If the current GPS time is not known, this packet is not sent at power-up or automatically.

**Note (2):** At turn-on, the Acutime sends packets 42 and 4A if the I/O single-precision-of-position option is selected and sends packets 83 and 84 if the I/O double-precision-of-position option is selected. At power-up, these packets are sent with negative time-of-fix.

**Note (3):** Channel A is silent unless a request for data is received. The automatic outputs shown above apply *only* to Channel B.

### 7.3.2.1 40 ALMANAC DATA PAGE

This packet provides almanac data for a single satellite. The Acutime sends this packet on request (packet 20 hex) and when the data is received from a satellite. The data format is shown below:

Byte #	Item	Type	Units
0	satellite	BYTE	(Identification Number)
1	T <sub>zc</sub>	SINGLE	Seconds
5	week number	INTEGER	Weeks
7	eccentricity	SINGLE	(Dimensionless)
11	T <sub>oa</sub>	SINGLE	Seconds
15	i <sub>o</sub>	SINGLE	Radians
19	OMEGA <sub>dot</sub>	SINGLE	Radians/Second
23	square root A	SINGLE	(Meters) <sup>1/2</sup>
27	OMEGA <sub>o</sub>	SINGLE	Radians
31	omega	SINGLE	Radians
35	M <sub>o</sub>	SINGLE	Radians

These symbols are defined in ICD-GPS-200.

T<sub>zc</sub> is normally positive. If no almanac data is available for this satellite, then T<sub>zc</sub> is negative. T<sub>zc</sub> and the week number in this packet refer to the Z-count time and week number at the time the almanac was received. The remaining items are described in the ICD-GPS-200.

**7.3.2.2 41 GPS TIME**

This packet provides the current GPS time of week and the week number. The Acutime sends this packet in response to packet 21 hex and during an update cycle. Update cycles occur every fifteen seconds when not doing fixes and occur every 150 seconds when doing fixes.

The data format is shown below:

Byte #	Item	Type	Units
0-3	GPS Time Of Week	SINGLE	Seconds
4-5	GPS Week Number	INTEGER	Weeks
6-9	GPS/UTC Offset	SINGLE	Seconds

**Note:** GPS time differs from UTC by a variable integral number of seconds  $UTC = (GPS \text{ time}) - (GPS/UTC \text{ offset})$ .

The GPS week number reference is week number zero starting January 6, 1980.

The seconds count begins with zero each Sunday morning at midnight. A negative indicated time-of-week indicates that time is not yet known. In that case, the packet is sent only on request. The following table shows the relationship between the information in packet 41, and the packet 46 status code.

Approximate Time Accuracy	Time Source	Sign (TOW)	Packet 46 Status Code
None	No Time At All	-	01 Hex
Unknown Approximate	Time From Real Time Clock or Packet 2E	+	01 Hex
20 to 50 msec + Clock Drift	Time from Satellite	+	Not 01 Hex
Full Accuracy	Time from GPS Solution	+	00 Hex

**Note:** Acutime has no real-time clock hardware. For the most accurate GPS time, before using the GPS time from packet 41, verify that the packet 46 status code is 00 hex (“Doing position fixes”).

**7.3.2.3 42 SINGLE-PRECISION POSITION FIX, XYZ ECEF**

This packet provides current GPS position fix in XYZ ECEF coordinates. If the I/O “position” option is set to “XYZ ECEF” and the I/O “precision-of-position output” is set to single-precision, then the Acutime sends this packet each time a fix is computed. The data format is shown below:

Byte #	Item	Type	Units
0-3	X	SINGLE	Meters
4-7	Y	SINGLE	Meters
8-11	Z	SINGLE	Meters
12-15	Time-of-Fix	SINGLE	Seconds

The time-of-fix is in GPS time or UTC as selected by the I/O “timing” option. At start-up, this packet or packet 83 is also sent with a negative time-of-fix to report the current known position. Packet 83 provides a double-precision version of this information.

**7.3.2.4 43 VELOCITY FIX, XYZ ECEF**

This packet provides current GPS velocity fix in XYZ ECEF coordinates. If the I/O “position” option is set to “XYZ ECEF, then the Acutime sends this packet each time a fix is computed if selected by the I/O “timing” option. The data format is shown below:

Byte #	Item	Type	Units
0-3	X Velocity	SINGLE	Meters/Second
4-7	Y Velocity	SINGLE	Meters/Second
8-11	Z Velocity	SINGLE	Meters/Second
12-15	Bias Rate	SINGLE	Meters/Second
16-19	Time-of-Fix	SINGLE	Seconds

The time-of-fix is in GPS time or UTC as selected by the I/O “timing” option.

**7.3.2.5 44 SATELLITE SELECTION**

This packet provides a list of satellites used for position fixes by the Acutime. The packet also provides the PDOP, HDOP, and VDOP of that set and provides the current mode (automatic or manual, 3-D or 2-D). The Acutime sends this packet in response to packet 24 hex and whenever a new satellite selection is attempted. The Acutime attempts a new selection every thirty seconds and whenever satellite availability and tracking status change. The data format is shown below.

Byte #	Item	Type	Value	Meaning
0	Mode	BYTE	01 Hex 03 Hex 04 Hex 11 Hex 13 Hex 14 Hex	Auto, 1-Satellite, 0-D Auto, 3-Satellite, 2-D Auto, 4-Satellite, 3-D Manual, 1-Satellite, 0-D Manual, 3-Satellite, 2-D Manual, 4-Satellite, 3-D
1-4	4 Satellite Numbers	4 BYTES		4 Satellite Numbers
5-8	PDOP	SINGLE		PDOP
9-12	HDOP	SINGLE		HDOP
13-16	VDOP	SINGLE		VDOP
17-20	TDOP	SINGLE		TDOP

PDOP value of zero indicates that the Acutime is not doing fixes, usually because there are not enough healthy usable satellites for position fixes. In this case, the satellite number list contains up to four of the satellites, which are usable. Empty satellite number-bytes contains 0. Negative PDOP values indicate that the PDOP is greater than the PDOP mask value and therefore the Acutime is not performing fixes.

**7.3.2.6 45 SOFTWARE VERSION INFORMATION**

This packet provides information about the version of software in the Navigation and Signal Processors. The Acutime sends this packet after power-on and in response to packet 1F hex. The data format is two 5 byte sequences, each of which has the format shown below.

Byte #	Item	Type
0	Major Version Number	BYTE
1	Minor Version Number	BYTE
2	Month	BYTE
3	Day	BYTE
4	Year Number Minus 1900	BYTE

The first 5 bytes refer to the navigation processor and the second 5 bytes refer to the signal processor.



## 7.3.2.7 46 HEALTH OF ACUTIME

This packet provides information about the satellite tracking status and the operational health of the Acutime. The Acutime sends this packet after power-on or software initiated resets, in response to packet 26 hex, during an update cycle, when a new satellite selection is attempted, and when the Acutime detects a change in its health. Packet 4B hex is always sent with this packet. The data format is given in the table on the following page.

Byte #	Item	Byte Type	Value	Meaning
0	Status Code	BYTE	00 Hex 01 Hex 02 Hex 03 Hex 08 Hex 09 Hex 0A Hex 0B Hex 0C Hex	Doing Position Fixes Don't Have GPS Time Yet Not Used PDOP is Too High No Usable Satellites Only One Usable Satellite Only 2 Usable Satellites Only 3 Usable Satellites The Chosen Satellite is Unusable (4)
1	Error Codes	BYTE		

The error codes are encoded into individual bits within the byte. The bit positions and their meanings are shown below:

Bit Position	Meaning if Bit Value = 1
0 (LSB)	Battery Back-Up Failed (1) (5)
1	Signal Processor Error (1)
2	Alignment Error, Channel or Chip 1 (1)
3	Alignment Error, Channel or Chip 2 (1)
4	Antenna Feed Line Fault (2)
5	Excessive Ref Freq. Error (3)
6	(Unused)
7 (MSB)	(Unused)

**Note (1):** After this error is detected, its bit remains set until the Acutime is reset.

**Note (2):** This bit follows the current status of the antenna feed line fault-detection circuitry. Since Acutime has an integral antenna assembly, this information is not important. It is only shown here for sake of completeness, being important for sensors with separate antennas.

**Note (3):** This bit is “one” if the last computed reference frequency error indicated that the reference oscillator is out of tolerance. (Packet 2D requests the oscillator offset and packet 4D returns the oscillator offset to the user.)

**Note (4):** This message occurs when the one-satellite mode is in effect and a specific satellite has been chosen with packet 34 hex but that satellite is unusable.

**Note (5):** This bit is always set, as the Acutime receiver battery backup is not installed.

**7.3.2.8 47 SIGNAL LEVELS FOR ALL SATELLITES**

This packet provides received signal levels for all satellites currently being tracked or on which tracking is being attempted (i.e., above the elevation mask and healthy according to the almanac). The Acutime sends this packet only in response to packet 27 hex. The data format is shown below:

Byte #	Item	Type
0	Count	BYTE
1	Satellite Number One	BYTE
2- 5	Signal Level One	SINGLE
6	Satellite Number Two	BYTE
7-10	Signal Level Two	SINGLE
(etc.)	(etc.)	(Etc.)

Up to twelve satellite number/signal level pairs may be sent, indicated by the count field. Signal level is normally positive. If it is zero, then that satellite has not yet been acquired. If it is negative, then that satellite is not currently in lock. The absolute value of signal level field is the last known signal level of that satellite.

The signal level provided in this packet is a linear measure of the signal strength after correlation or spreading.

**7.3.2.9 48 GPS SYSTEM MESSAGE**

This packet provides the 72 byte ASCII message carried in the GPS satellite navigation message. The Acutime sends this packet in response to packet 28 hex and when this data is received from a satellite.

The message is a bulletin board from the Air Force to GPS users. The format is free-form ASCII. The message may be blank.

**7.3.2.10 49 ALMANAC HEALTH PAGE**

This packet provides health information on thirty-two satellites. Packet data consists of 32 bytes each containing the 6 bit health from almanac page twenty-five. The first byte is for satellite number one, and so on. The Acutime sends this packet in response to packet 29 hex, and when this data is received from a satellite.

Byte #	Item
1	Health of Satellite Number One
2	Health of Satellite Number Two
.	.
.	.
.	.
32	Health of Satellite Number Thirty-Two

In each data byte of this packet, a value “0” indicates that the satellite is healthy. All other values indicate that the satellite is unhealthy.

**7.3.2.11 4A SINGLE-PRECISION LLA POSITION FIX**

This packet provides current GPS position fix in LLA (latitude, longitude, and altitude) coordinates. If the I/O “position” option is set to “LLA” and the I/O “precision-of-position output” is set to single-precision, then the Acutime sends this packet each time a fix is computed. The data format is shown below:

Byte #	Item	Type	Units
0-3	Latitude	SINGLE	Radians; + For North, - For South
4-7	Longitude	SINGLE	Radians; + For East, - For West
8-11	Altitude	SINGLE	Meters
12-15	Clock Bias	SINGLE	Meters
16-19	Time-of-Fix	SINGLE	Seconds

Altitude is referred to the WGS-84 ellipsoid or the MSL Geoid, depending on which I/O “LLA altitude” option is selected.

The time-of-fix is in GPS time or UTC, depending on which I/O “timing” option is selected.

This packet also is sent at start-up with a negative time-of-fix to report the current known position.

Packet 84 provides a double-precision version of this information.

**\* \* \* CAUTION \* \* \***

When converting from radians to degrees, significant and readily visible errors will be introduced by use of an insufficiently precise approximation for the constant p(PI). The value of the constant PI as specified in ICD-GPS-200 is 3.1415926535898

**7.3.2.12 4B MACHINE/CODE ID AND ADDITIONAL STATUS**

The Acutime transmits this packet in response to packets 25 and 26 and following a change in state. In conjunction with packet 46, “Health of Acutime,” this packet identifies the Acutime and may present error messages. The machine ID can be used by equipment communicating with the Acutime to determine the type of Acutime to which the equipment is connected. Then the interpretation and use of packets can be adjusted accordingly.

Byte #	Item	Type	Value	Meaning
0	Machine ID	BYTE	1B	Six Channel Acutime
1	Status 1	BYTE		

The error codes are encoded into individual bits within the byte. The bit positions and their meanings are shown below:

Bit Position	Meaning if bit value = 1		
0 (LSB)	Synthesizer Fault		
1	Battery Powered Time Clock Fault		
2	A-to-D Converter Fault (Not Used)		
3	The almanac stored in the Acutime, is not complete and current.		
4-7	Not Used		
2	Status 2	BYTE	Super Packets Supported

**7.3.2.13 4C REPORT OPERATING PARAMETERS**

This packet provides several operating parameter values of the Acutime. The Acutime sends this packet in response to packet 2C hex. The data format is shown on the following page.

The dynamics code indicates the expected vehicle dynamics and is used to assist the initial solution.

The elevation angle mask determines the lowest angle at which the Acutime tries to track a satellite.

The signal level mask sets the required signal level for a satellite to be used for position fixes.

The PDOP mask sets the maximum PDOP with which position fixes are calculated. The PDOP switch sets the threshold for automatic 3-D/2-D mode. If four or more satellites are available and the resulting PDOP is not greater than the PDOP mask value, then three dimensional fixes are calculated.

Byte #	Item	Type	Units	Default
0	Dynamics Code	BYTE		
Value	Meaning	Assumed Velocity		
0	Current value is left unchanged.			
1	Land	< 120 Knots		
2	Sea	< 50 Knots		
3	Air (Default)	< 800 Knots		
4	Static	Stationary		
Byte #	Item	Type	Units	Default
1-4	Elevation Angle Mask	SINGLE	Radians	0.1745 or 10°
5-8	Signal Level Mask	SINGLE	---	6
9-12	PDOP Mask	SINGLE	---	12
13-16	PDOP Switch (3-D or 2-D)	SINGLE	---	8

A negative value in a SINGLE field leaves that current setting unchanged.

This information is held in battery-backed memory.

**7.3.2.14 4D OSCILLATOR OFFSET**

This packet provides the current value of the Acutime master oscillator offset in hertz at carrier. This packet contains one *single* number. The Acutime sends this packet in response to packet 2D hex. The permissible offset varies with the Acutime unit.

**7.3.2.15 4E RESPONSE TO SET GPS TIME**

Indicates whether the Acutime accepted the time given in a set GPS time packet. The Acutime sends this packet in response to packet 2E hex. This packet contains 1 byte.

Value	Meaning
ASCII "Y"	The Acutime accepts the time entered via packet 2E. The Acutime has not yet received the time from a satellite.
ASCII "N"	The Acutime does not accept the time entered via packet 2E. The Acutime has received the time from a satellite and uses that time. The Acutime disregards the time in packet 2E.

**7.3.2.16 54 ONE-SATELLITE BIAS AND BIAS RATE**

The Acutime sends this packet to provide the computed clock-only solution when the Acutime is in the manual or automatic one-satellite mode.

Byte	Item	Type	Units
0-3	Bias	SINGLE	Meters
4-7	Bias Rate	SINGLE	Meters/Second
8-11	Time of Fix	SINGLE	Seconds

The bias is the offset of the Acutime internal time clock from GPS time. Bias is expressed as meters of apparent range from the satellites. It is used to correct the 1pps output. Bias rate is the frequency error of the Acutime internal oscillator. It is expressed as apparent range rate.

**\* \* \* CAUTION \* \* \***

For accurate interpretation of the propagation delay, the precise constant for the speed of light must be used. The WGS-84 value for the speed of light is 299,792,458 meters per second.

## 7.3.2.17 55 I/O OPTIONS

This packet provides current I/O options in effect in response to packet 35 request. The data format is the same as for packet 35 hex and is repeated below for convenience.

Byte Number	Parameter Name	Bit Position	Bit Value	Default Option	Associated Packet
0	Position	0 (LSB)	1	XYZ ECEF Output 0: Off 1: On	42 or 83
		1	0	LLA Output 0: Off 1: On	4A or 84 or 8F-01 or 8F-02
		2	0	LLA ALT Output 0: HAE WGS-84 1: MSL Geoid	
		3	0	ALT Input 0: HAE WGS-84 1: MSL Geoid	2A
		4	0	Precision-of-Position Output 0: Send single-precision packet 42 and/or 4A. 1: Send double-precision packet 83 and/or 84.	
		5	0	Super Packet Output 0: Off 1: On	
		6	0	Super Packet Format 0: Binary 1: ASCII	
		7	0	Unused	

**Note:** If bit 5 is 0 then no super packets are output. If bits 5 and 6 are 1 then packet 8E-01 is output. If bit 5 is 1 and 6 is 0 then packet 8F-02 is. If super packet output is selected then 8F-01 or 8F-02 packets are output instead of the standard 4A or 84 packets.

SIGNAL CHARACTERISTICS

Byte Number	Parameter Name	Bit Position	Bit Value	Default Option	Associated Packet
1	Velocity	1		XYZ ECEF Output 0: Off 1: On	43
		1	0	ENU Output 0: Off 1: On	56
		2-7	0	Unused	
2	Timing	0	0	Time Type 0: GPS Time 1: UTC	
		1	0	Fix Computation Time 0: ASAP 1: Next Integer Sec	
		2	0	Output Time 0: When Computed 1: Only on Request	37
		3	0	Synchronized Measurements (V1.14 Onwards) 0: Off 1: On	
		4	0	Minimize Projection (V1.14 Onwards) 0: On 1: Off	
		5-7	0	Unused	
3	Auxiliary	0	0	Raw Measurements 0: Off 1: On	5A
		1	0	Doppler Smoothed Code Phase (V1.14 Onwards) 0: Raw 1: Smoothed	
		2	0	Additional Fix Status (V1.12 Onwards) 0: Off 1: On	
		3-7		Unused	



## CHAPTER SEVEN

Glossary for the table on the previous page:

### **ALT**

Altitude.

### **ECEF**

Earth-Centered, Earth-Fixed.

### **XYZ**

Cartesian Coordinates.

### **LLA**

Latitude, Longitude, Altitude.

### **HAE**

Height Above Ellipsoid.

### **WGS-84**

Earth Model (Ellipsoid).

### **MSL geoid**

Earth (Mean Sea Level) Model.

### **ENU**

East-North-Up (Same as LLA).

### **UTC**

Universal Coordinated Time.

### **7.3.2.18 56 VELOCITY FIX, EAST-NORTH-UP (ENU)**

If East-North-Up (ENU) coordinates have been selected for the I/O “position” option, the Acutime sends this packet under the following conditions: (1) each time that a fix is computed. (2) in response to packet 37 hex (last known fix). The data format is shown below.

<b>Byte #</b>	<b>Item</b>	<b>Type</b>	<b>Units</b>
0-3	East Velocity	SINGLE	m/s; + for east, - for west
4-7	North Velocity	SINGLE	m/s; + for north, - for south
8-11	Up Velocity	SINGLE	m/s; + for up, - for down
12-15	Clock Bias Rate	SINGLE	m/s
16-19	Time-of-Fix	SINGLE	seconds

The time-of-fix is in GPS or UTC time as selected by the I/O “timing” option.

### 7.3.2.19 57 INFORMATION ABOUT LAST COMPUTED FIX

This packet provides information concerning the time and origin of the previous position fix. The Acutime sends this packet, among others, in response to packet 37 hex. The data format is shown below:

Byte #	Item	Type	Units
0	Source of Information	BYTE	---
<b>Value</b>		<b>Meaning</b>	
	00 Hex	None	
	01 Hex	Regular Fix	
	02 Hex	Initialization Diagnostic	
	04 Hex	Initialization Diagnostic	
	05 Hex	Entered by Packet 23 Or 2b	
	06 Hex	Entered by Packet 31 Or 32	
	08 Hex	Default Position After Ram Battery Fail	
Byte #	Item	Type	Units
1	Manuf. Diagnostic	BYTE	---
2-5	Time of Last Fix	SINGLE	Seconds, GPS Time
6-7	Week of Last Fix	INTEGER	Weeks, GPS Time

### 7.3.2.20 58 SATELLITE SYSTEM DATA/ACKNOWLEDGE FROM ACUTIME

This packet provides GPS data (almanac, ephemeris, etc.). The Acutime sends this packet under the following conditions: (1) on request. (2) in response to packet 38 hex (acknowledges the loading of data). The data format is shown below.

Byte #	Item	Type	Byte Value	Meaning
0	Operation	BYTE	0	Acknowledge, Can't Use
			1	Acknowledge
			2	Data Out
			3	No Data on SV
1	Type of Data	BYTE	1	Not Used
			2	Almanac
			3	Health page, T_oa, WN_oa
			4	Ionosphere
			5	UTC
			6	Ephemeris

Byte #	Item	Type	Byte Value	Meaning
2	Sat PRN #	BYTE	0	Data that is not Satellite-ID-Specific
			1-32	Satellite PRN Number
3	length ( <i>n</i> )	BYTE		Number of Bytes of Data to be Loaded
4 to n+3	dat	<i>n</i> BYTES		

### 7.3.2.21 59 STATUS OF SATELLITE DISABLE OR IGNORE HEALTH

Normally the Acutime selects satellites for use in GPS solution according to whether the candidate satellites are in good health and whether they satisfy the mask values for elevation angle, signal level, and PDOP. This packet reads back whether the user has told the Acutime to disable unconditionally the selection of any particular satellite and whether the user has told the Acutime to ignore the health of any particular satellite that otherwise is acceptable for selection. The Acutime sends this packet in response to packet 39 hex. The data format is shown below.

Byte #	Item	Type	Byte Value	Meaning
0	Operation	BYTE	3	The remaining byte tells whether or not the Acutime is allowed to select each satellite.
			6	The remaining bytes tell whether or not the Acutime heeds or ignores each satellite's health as a criterion for selection.
1 to 32	Satellite #	*32 BYTES	0	Enable satellite selection or heed satellite's health. Default value.
			1	Disable satellite selection or ignore satellite's health.

\* 1 byte per satellite.

This information is *not* held in battery-backed memory. At power-on and after a reset, the default values are set for all satellites.

### 7.3.2.22 5A RAW MEASUREMENT DATA

This packet provides raw GPS measurement data. If the I/O “auxiliary” option has been selected, the Acutime sends this data automatically as measurements are taken. The Acutime also sends this packet in response to packet 3A hex. The data format is shown below:

Byte #	Item	Type	Units
0	Satellite PRN Number	BYTE	-----
1	Sample Length	SINGLE	msec
5	Signal Level	SINGLE	
9	Code Phase	SINGLE	1/16th chip
13	Doppler	SINGLE	Hertz
17	Time of Measurement	DOUBLE	sec

#### Application Note

Packet 5A provides the raw satellite signal measurement information used in computing a fix.

The *satellite PRN* (Byte 0) number is a unique identification for each of the thirty-two GPS satellites.

The *sample length* (Byte 1) is the number of milliseconds over which the measurement was averaged. Thus if the sample length is 428, then the receiver tracked the satellite and collected the measurement over a 428 millisecond period. Acutime uses a 500 millisecond dwell time per satellite, however, if the channel is sequencing on several satellites, the sample length will be closer to 400 milliseconds due to reacquisition and loop setting times.

The *signal level* (Byte 5) is a linear approximation of C/N0, which is stated in antenna amplitude measurement units (AMU's), a Trimble devised unit. An approximate correlation of AMU levels to C/N0 follows:

5 AMU's	-20 dB SNR
16 AMU's	-10 dB SNR or AMU's 51 *
26 AMU's	-5 dB SNR

The C/N0 is affected by five basic parameters: 1) signal strength from the GPS satellite, 2) receiver/antenna gain, 3) pre-amplifier noise figure, 4) receiver noise bandwidth, and 5) accumulator sample rate and statistics. The approximation is very accurate from zero to twenty-five AMU's.

## CHAPTER SEVEN

The *code phase* (Byte 9) value is the average delay over the sample interval of the received C/A code and is measured with respect to the receiver's millisecond timing reference. Thus, it includes all receiver, satellite, and propagation biases and errors. It is expressed in 1/16th of a C/A code chip.

The *Doppler* (Byte 13) value is apparent carrier frequency offset averaged over the sample interval. It is measured with respect to the nominal GPS L1 frequency of 1575.42 MHz, referenced to the receiver's internal oscillator (TCXO). Thus, it includes all receiver and satellite clock frequency errors. It is expressed in hertz at the L1 carrier.

The *time-of-measurement* (Byte 17) is the center of the sample interval and measured by adding the Acutime supplied code phase (modulo mS) to a user determined integer number of mS between user and satellite.

Since the Acutime code phase resolution is 1/16th of a C/A code chip, this corresponds to:

$$\begin{array}{lll} 1/16 * \text{C/A code chip} & 977.517\text{ns}/16 & 61.0948 \text{ ns} \\ & & 61.0948 * \text{speed of light, m/s} \\ & & 18.3158 \text{ meter} \end{array}$$

The integer millisecond portion of the pseudo-range must then be derived by utilizing the approximate user and satellite positions. Rough user position (within a few hundred kilometers) must be known. The satellite position can be found in its almanac/ephemeris data.

Each mS integer corresponds to:

$$\begin{array}{lll} \text{C/A code epoch} * \text{speed of light} & = & 1 \text{ ms} * \text{speed of light, m/s} \\ & & 300\text{km (approx.)} \\ & & 299.792458 \text{ km (precise)} \end{array}$$

### 7.3.2.23 5B SATELLITE EPHEMERIS STATUS

This packet is sent in response to packet 3B and when a new ephemeris (based on IODE) is received. It contains information on the status of the ephemeris in the receiver for a given satellite. The structure of packet 5B is as follows:

Byte #	Item	Type	Meaning or Units
0	SV PRN Number	BYTE	
1-4	Time of Collection	REAL	Seconds
5	Health	BYTE	
6	IODE	BYTE	
7	toe	REAL	Seconds
11	Fit Interval Flag	BYTE	
12-15	SV Accuracy (URA)	REAL	Meters

SV PRN Number is from one to thirty-two representing the satellite PRN number. Time of Collection is the GPS time when this ephemeris data was collected from the satellite. Health is the 6 bit ephemeris health. IODE, toe, and Fit Interval Flag are as described in ICD-GPS-200. SV Accuracy (URA) is converted to meters from the 4 bit code as described in ICD-GPS-200.

**7.3.2.24 5C SATELLITE TRACKING STATUS**

This packet provides tracking status data for a specified satellite. Some of the information is very implementation dependent and is provided mainly for diagnostic purposes. The Acutime sends this packet in response to packet 3C hex. The data format is shown below:

Byte #	Item	Type	Units
0	Satellite PRN Number	BYTE	Number, 1 to 32
1	Channel and Slot Code	BYTE	

This is an internal coding of the hardware tracking channel and of the slot within the channel to which the specified satellite currently is assigned.

Bit Position	Value	Meaning
2 to 0 (LSB)	<u>210</u>	
	000 (LSB)	slot 1
	001	slot 2
	010	slot 3
	011	slot 4
	100	slot 5
	101	slot 6

7(MSB) to 3: channel number, starting with zero

Bits 7-3	Channel	Used by
00000	1	All Acutime
00001	2	6-channel Acutime Only
00010	3	6-channel Acutime Only
00011	4	6-channel Acutime Only
00100	5	6-channel Acutime Only
00101	6	6-channel Acutime Only
76543		

CHAPTER SEVEN

Byte #	Item	Type	Units
2	Acquisition Flag	BYTE	
<b>Byte Value</b>		<b>Meaning</b>	
0		Never Acquired	
1		Acquired	
2		Re-opened Search	
Byte #	Item	Type	Units
2	Ephemeris Flag	BYTE	
<b>Byte Value</b>		<b>Meaning</b>	
0		Flag Not Set	
0		Good Ephemeris for this Satellite (<4 Hours Old, Good Health)	
Byte #	Item	Type	Units
4-7	Signal Level	SINGLE	Same As In Packet 46 Hex
8-11	GPS Time Of Last Msmt	SINGLE	Seconds
<b>Byte Value</b>		<b>Meaning</b>	
<0		No Measurements Have Been Taken	
≥0		Center of the last measurement was taken from this satellite.	
Byte #	Item	Type	Units
12-15	Elevation	SINGLE	Radians

Approximate elevation of this satellite above the horizon. Updated about every fifteen seconds. Used for searching and computing measurement correction factors.

Byte #	Item	Type	Units
16-19	Azimuth	SINGLE	Radians

Approximate azimuth from true north to this satellite. Updated typically about every three to five minutes. Used for computing measurement correction factors.

Byte #	Item	Type	Units
20	Old Measurement Flag	BYTE	

SIGNAL CHARACTERISTICS

Byte Value		Meaning	
0		Flag Not Set	
>0		The last measurement is too old to use for a fix computation.	
Byte #	Item	Type	Units
21	Integer msec Flag	BYTE	
Byte Value		Meaning	
0		Don't have good knowledge of this integer millisecond range to this satellite.	
1		Msec from sub-frame data collection.	
2		Verified by a bit crossing time.	
3		Verified by a successful position fix.	
4		Suspected msec error.	
Byte #	Item	Type	Units
22	Bad Data Flag	BYTE	
Byte Value		Meaning	
0		Flag Not Set	
1		Bad Parity	
2		Bad Ephemeris Health	
Byte #	Item	Type	Units
23	Data Collect Flag	BYTE	
Byte Value		Meaning	
0		Flag Not Set	
>0		The Acutime is currently trying to collect data from this satellite.	



**7.3.2.25 5E ADDITIONAL FIX STATUS**

This packet describes attributes of a position fix. The information is requested by packet 3E or sent after each fix if bit two of AUX BYTE in packet 35 is set.

Byte	Bit	Meaning
0	0-2	Number of measurements in current fix that were used in a previous fix.
	3	1: No differential Doppler velocity available.
		0: Differential Doppler velocity available.
	4	1: Fix still converging (when status code =, i.e. doing fixes).
0: Fix converged.		
1	5-7	Unused
	0-2	Number of measurements in current fix that are old (3-5 s).
	3-7	Unused

**7.3.2.26 5F FAILURE REPORT**

If a severe failure prevents the Acutime from operating, the Acutime sends this packet at turn-on if the failure does not preclude doing so. Generally, the Acutime sends nothing following this packet. The packet data bytes consist of “02” followed by an ASCII text message, which describes the failure.

**7.3.2.27 6D ALL-IN-VIEW SATELLITE SELECTION**

This packet provides a list of satellites used for position fixes by the Acutime. The packet also provides the PDOP, HDOP, and VDOP of that set and provides the current mode (automatic or manual, 3-D or 2-D). The Acutime sends this packet in response to packet 24 hex and whenever a new satellite selection is attempted. The Acutime attempts a new selection every thirty seconds and whenever satellite availability and tracking status change. If four satellites are being used to generate a 3D position or three satellites for a 2D position, packet 44 is sent instead of 6D, however; if more than four satellites are being used to generate the position, packet 6D is sent instead of packet 44, so it is recommended that the user listen for both packets.

This packet has variable length equal to 16+nsvs (minimum four), where “nsvs” is the number of satellites used in the solution. The data format is shown below.

**Note:** Supported only in TSIP core code version 1.16 and later.

Byte #	Item	Type	Bit	Value	Meaning
0	Mode	BYTE	0-2	3	2D
				4	3D
			3	0	Auto
				1	Manual
			4-7	- -	nsys
1-4	PDOP	SINGLE			PDOP
5-8	HDOP	SINGLE			HDOP
9-12	VDOP	SINGLE			VDOP
13-16	TDOP	SINGLE			TDOP
(16+NSVS)	SV PRN	BYTE			

### 7.3.2.28 76 BEST 4/HIGH 6/SMART 8 - MODE

This packet shows whether the Acutime is in High-6 or High-8 mode. It returns 1 byte:

This packet is sent in response to packet 75 hex.

- 0 = Best 4 Mode
- 1 = High 6 (Over Determined) Mode (Default Mode for the Acutime)
- 2 = Smart 8 (Over Determined Smart Sequencing) Mode

### 7.3.2.29 82 DIFFERENTIAL POSITION FIX MODE

This packet provides the differential position fix mode of the Acutime. This packet contains only 1 data byte to specify the mode.

This packet is sent in response to packet 62 and whenever a satellite selection is made and the mode is Auto GPS/GPD (modes 2 and 3).

The Acutime switches automatically between modes 2 and 3 based on the availability of differential corrections for a constellation, which meets all other masks. If such a constellation is not available, then the Acutime stays in its current automatic mode (2 or 3), and does not do position solutions.

Valid modes are:

- 0 Manual GPS (Differential off)
- 1 Manual GPD (Differential on)
- 2 Auto GPS (Differential currently off)
- 3 Auto GPD (Differential currently on)

## CHAPTER SEVEN

“Manual GPS” (mode 0) means that the Acutime does position solutions without differential corrections, even if the differential corrections are available.

“Manual GPD” (mode 1) means that the Acutime only does position solutions if valid differential correction data is available.

“Automatic GPS” (mode 2) means that the Acutime is not receiving differential correction data for all satellites in constellation which meets all other masks, and is doing non-differential position solutions.

“Automatic GPD” (mode 3) means that the Acutime is receiving differential correction data for all satellites in a constellation which meets all other masks, and is doing differential position solutions.

### 7.3.2.30 83 DOUBLE-PRECISION XYZ POSITION FIX AND BIAS INFORMATION

This packet provides current GPS position fix in XYZ ECEF coordinates. If the I/O “position” option is set to “XYZ ECEF” and the I/O double-precision-of-position option is selected, the Acutime sends this packet each time a fix is computed. The data format is shown below:

Byte #	Item	Type	Units
0-7	X	DOUBLE	Meters
8-15	Y	DOUBLE	Meters
16-23	Z	DOUBLE	Meters
24-31	Clock Bias	DOUBLE	Meters
32-35	Time-of-Fix	SINGLE	Seconds

The time-of-fix is in GPS time or UTC, as selected by the I/O “timing” option. At start-up, if the I/O double-precision-of-position option is selected, this packet is also sent with a negative time-of-fix to report the current known position.

Packet 42 provides a single-precision version of this information.

### 7.3.2.31 84 DOUBLE-PRECISION LLA POSITION FIX AND BIAS INFORMATION

This packet provides current GPS position fix in LLA coordinates. If the I/O “position” option is set to “LLA” and the double-precision-of-position option is selected, the Acutime sends this packet each time a fix is computed. The data format is shown next page.

Byte #	Item	Type	Units
0-7	Latitude	DOUBLE	Radians; + for north, - for south
8-15	Longitude	DOUBLE	Radians; + for east, - for west
16-23	Altitude	DOUBLE	Meters
24-31	Clock Bias	DOUBLE	Meters
32-35	Time-Of-Fix	SINGLE	Seconds

The time-of-fix is in GPS time or UTC, as selected by the I/O “timing” option. At start-up, this packet is also sent with a negative time-of-fix to report the current known position.

Packet 4A provides a single-precision version of this information.

\* \* \* CAUTION \* \* \*

When converting from radians to degrees, significant and readily visible errors will be introduced by use of an insufficiently precise approximation for the constant p (pl). The value of the constant Pl as specified in ICD-GPS-200 is 3.145926535898.

**7.3.2.32 85 DIFFERENTIAL CORRECTIONS STATUS**

This packet provides the status of differential corrections for a specific satellite. It is sent in response to packet 65. The format of this packet is as follows:

Byte	Item	Type	Units
0	Satellite PRN Number	BYTE	
1	Summary Status Code	BYTE	
2	Station Health	BYTE	
3	Satellite Health (UDRE)	BYTE	
4	IODE 1	BYTE	
5	IODE 2	BYTE	
6	Z-count as Time-of-Week	SINGLE	Seconds
10	Range Correction	SINGLE	Meters
14	Range-Rate Correction	SINGLE	m/sec
18	Delta Range Correction	SINGLE	Meters

## CHAPTER SEVEN

The summary status code is encoded as follows:

- 0 Good Correction Data
- 1 Good Delta Correction Data
- 2 Station Health Bad (Five or Seven)
- 3 Data Too Old (Sixty seconds)
- 4 UDRE too high (>4)
- 5 IODE mismatch with ephemeris

## CHAPTER EIGHT

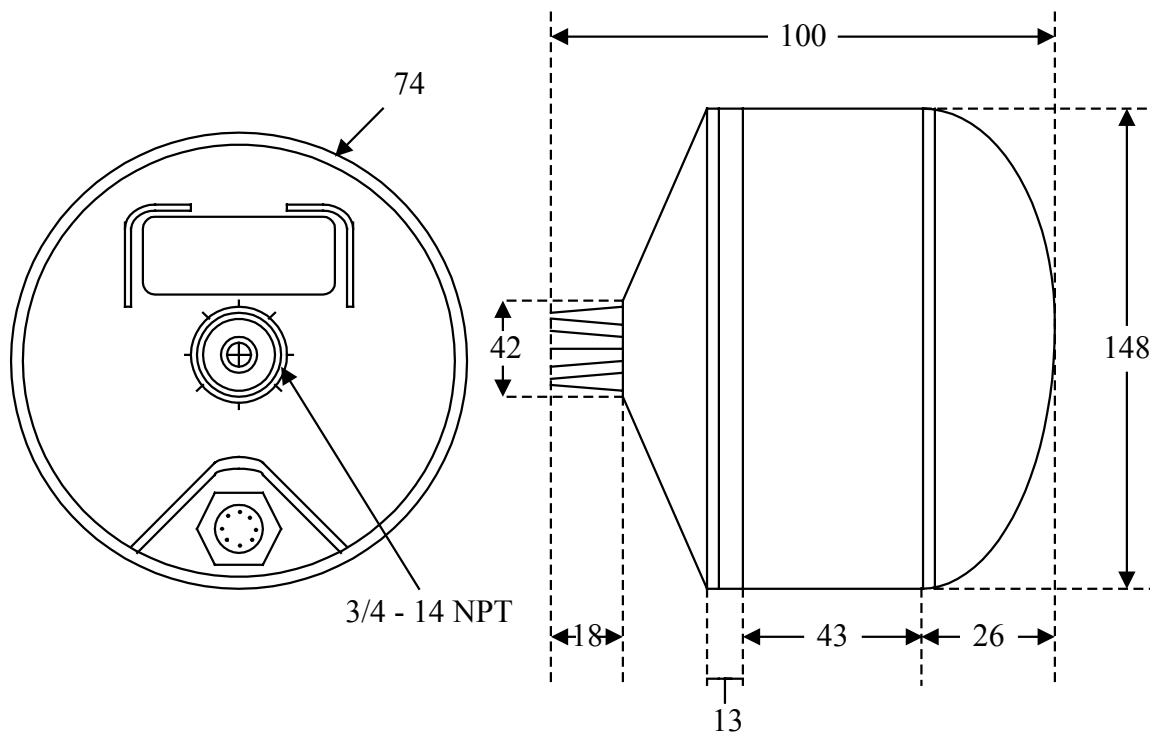
### APPLICATION NOTES

#### 8.0 GENERAL

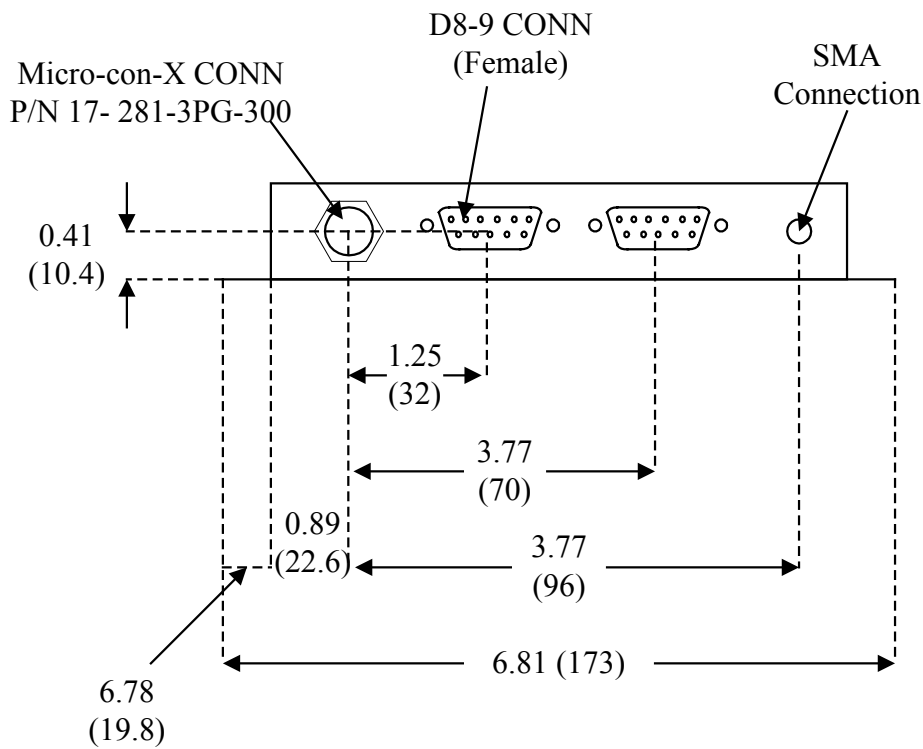
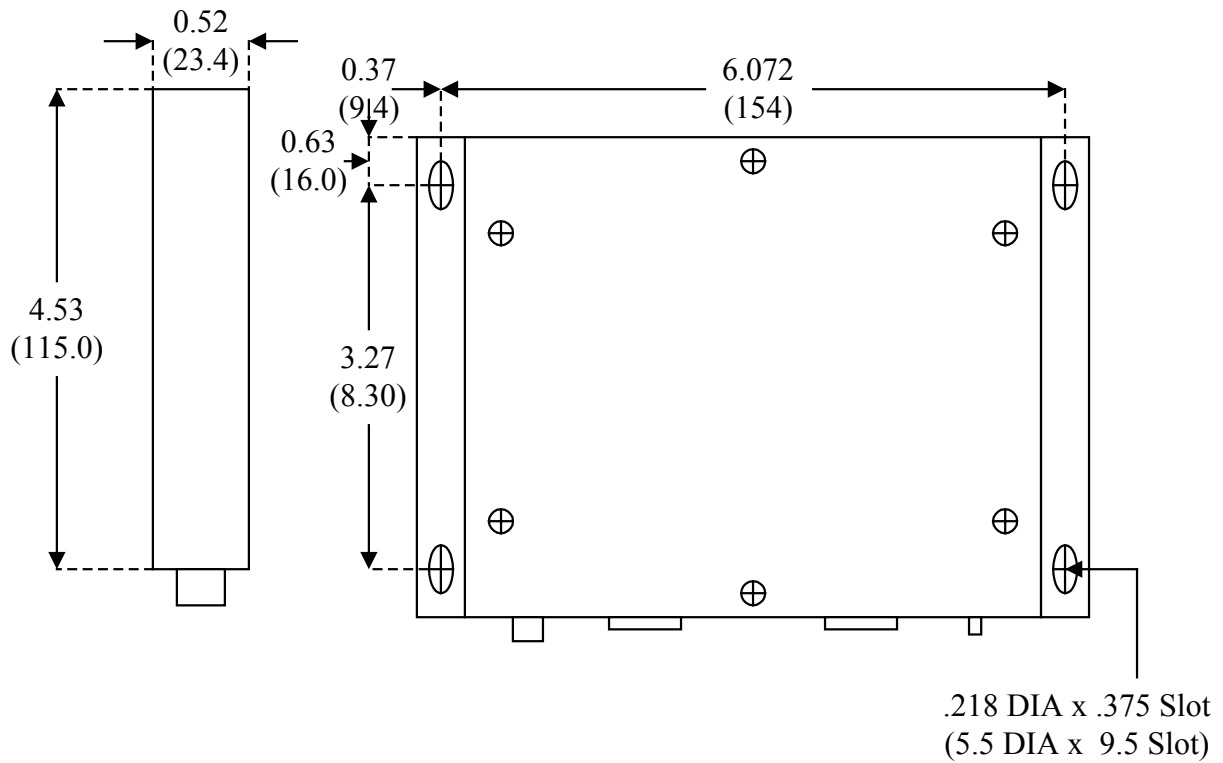
Symmetricom's standard bus level GPS products are the bc627AT, the bc637VME, bc257PCI, and the bc357VXI, which correspond to the PC ATbus, VMEbus, PCI bus and VXIbus, respectively. These normally utilize the combination receiver/antenna show in Figure One. This package is not suitable for mounting beneath a protective radome.

For all three board level products, Symmetricom offers an airborne option, -AANT. This option utilizes a separate receiver package (see Figure Two) and an airborne antenna (see Figure Three.) Fifty feet of RF cable is supplied to connect the antenna to the receiver package and ten feet of power/data cable is supplied. Cables are supplied with mating connectors. Power is derived from the host of Symmetricom's bus level time and frequency processing module.

**Figure One**  
**Standard Receiver/Antenna Unit**

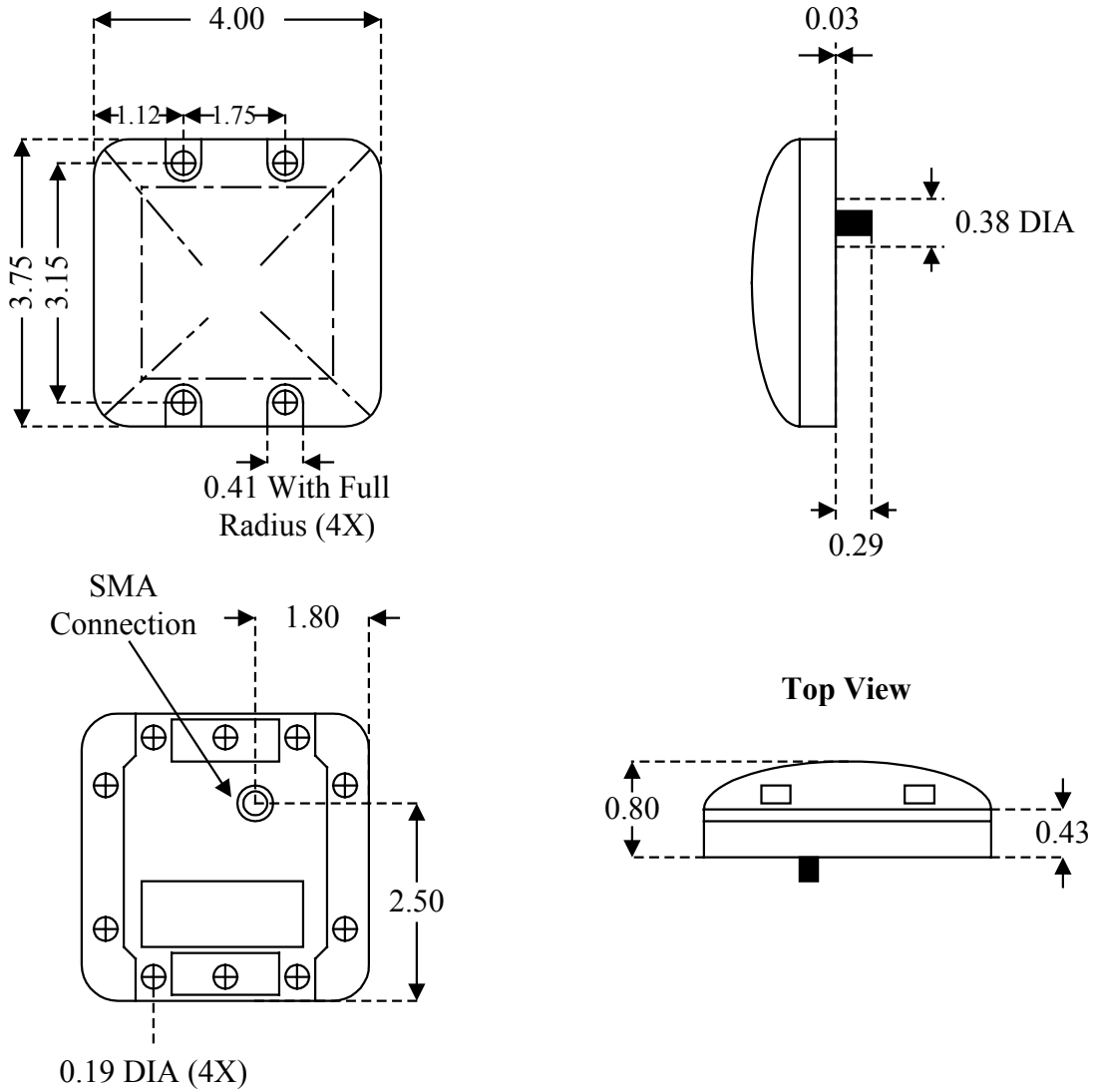


**Figure Two  
Receiver Unit**



Note: Unless otherwise specified, dimensions are in inches. Millimeters are in parenthesis.

**Figure Three  
Antenna Unit**





## CHAPTER EIGHT

Symmetricom Inc, Bancomm-Timing Division produces a variety of precision timing modules that interface to computer workstations via VMEbus, PCbus, PCIbus or network connections. These products are summarized as follows:

VME	bc637VME GPS Satellite Receiver
VXI	bc357VME GPS Satellite Receiver
PC	bc627AT GPS Satellite Receiver
PCI	bc637PCI GPS Satellite Receiver
Network	TymServe 2100 GPS Network Time Server, GPS Version

In their standard configuration, all of these products use the Trimble “Acutime” antenna/receiver unit. (See Figure One.) This article describes the salient technical characteristics of the Acutime GPS antenna/receiver.

In addition to interfacing to the Acutime, all of the above Symmetricom products can be interfaced to an airborne and separate receiver module. Contact Symmetricom (see back cover of User’s Guide for details) for more information.

**\* \* \* SPECIAL NOTE \* \* \***

The following pages were taken from Trimble’s GPS Acutime Sensor Manual, Revision Number Five, May 1992. Modifications have been made to the section numbers, and to some of the text.

### 8.1 INTRODUCTION

This document covers the specification of the GPS Acutime self contained six channel GPS position and timing sensor for incorporation into a variety of system designs including tracking and data communications. The GPS Acutime sensor is available with options to match system integrators’ needs. These options cover interfacing protocols, external battery backup, timing outputs and mechanical mounting.

Trimble has a long term commitment to the production of the highest quality and performance GPS units in the world, the result of our strategy of high investment in Research and Development. On the manufacturing side Trimble has installed one of the most advanced automated surface mount technology flow line systems in the world which gives the benefits of low labor content and high quality. We are working to integrate tightly our CAD design and manufacturing CIM functions. In future we will be able to respond rapidly to design variations requested by clients.

The flow line has automated visual image feedback control for the pick and place operation which means very low rejection and rework rates. We are thus able to supply units to the highest standards available and a virtually any scale of production envisaged.

## **8.2 GENERAL DESCRIPTION**

### **GPS Acutime Antenna/Receiver assembly**

Trimble offers the self contained GPS Acutime unit with a digital interface. This requires only a DC voltage source to operate, providing position, velocity and a 1pps output every second together with a hex output of UTC time. GPS Acutime is designed to be a zero maintenance unit readily able to interface with a wide variety of equipment. The maintenance objective has been achieved by mounting the antenna and receiver board sub-assembly in a sealed white lexan housing. Trimble's long experience in marine GPS has shown that the antenna seal joint is the weakest link, being subject to extreme shear forces when the housing is struck by green water or ice chunks breaking loose from masts or rigging. We have thus eliminated this source of potential problems in the GPS Acutime design.

## **8.3 SYSTEM DEFINITION**

### **8.3.1 GENERAL FUNCTIONAL DESCRIPTION**

The six channels Trimble Acutime GPS Sensor Antenna/Receiver is designed as a GPS SPS (Standard Positioning Service) unit, which uses the C/A, code on the L1 frequency carrier. The GPS Acutime internally calculates worldwide, day-and-night, all-weather position. Position accuracy is specified at twenty-five meters spherical error probability (SEP) and velocity accuracy is specified at 0.02 meters/second under moderate dynamic conditions. The DoD reserves the right to implement selective availability (SA) of accuracy. Under these conditions, position accuracy will be degraded to one hundred meters (2 dRMS) and velocity accuracy will also be reduced.

The system receives GPS satellite signals using a fixed-pattern crossed dipole antenna mounted above the receiver board. The sensor uses six processing channels to compute three-dimensional position and velocity and to manage and maintain the satellite tracking process. The GPS Acutime interfaces for data output with other equipment provided by the customer using the digital protocols described below. The GPS Acutime automatically selects the satellites which it tracks and is completely self-initializing from a cold start, loading almanac data from the first satellite available. An option is provided to allow the memory to be supported externally during power-off periods. Startup from power-on is then thirty - forty-five seconds.

## CHAPTER EIGHT

### 8.3.2 ABBREVIATED SPECIFICATIONS

#### 1 PPS accuracy

Ten microseconds. A dwell time of two to three minutes after satellite lock-on is needed before the 1pps output is within specification.

#### Position accuracy

Twenty-five meters spherical error probability (SEP), one hundred meters (2 dRMS) if selective availability (SA) is enabled.

#### Symmetricom

WGS-84 standard, Other Symmetricom available to order.

#### Velocity accuracy

0.02 m/sec without SA.

#### Reaction time

2.5 - 3.5 minutes (average), thirty to forty-five seconds with memory backup.

#### Data I/O

Option 1 (TSIP) Trimble Standard Interface Protocol. (TANS)

Option 2 (TAIP) Trimble ASCII Interface Protocol

Option 3 NMEA0183 unidirectional. Outputs to be specified at ordering.

#### Election I/O

RS-422, RS-232.

#### Differential GPS

RTCM SC104 protocol input. See below for connections.

#### Dynamic capability

Electrical only.

<u>Velocity</u>	<u>Acceleration</u>	<u>Jerk</u>
400 m/sec	4 g (39.2 m/sec <sup>2</sup> )	20 m/sec <sup>3</sup>

The unit will not give fully accurate 1pps output unless it is installed in a static environment.

**Temperature**

Operating	-40°C to + 71°C
Non-operating	-55°C to + 84°C

**Humidity**

100% condensing.

**Prime power**

10/32 VDC-2 watts nominal-Inline fuse (3A Quick Blow-to be supplied by customer externally).

The GPS Acutime is compatible with both twelve and twenty-four volt DC systems. The GPS Acutime has an over-voltage protection circuit designed to trip at voltages exceeding thirty-six volts. Conditions may cause the in-line fuse to blow. The protection circuit automatically resets upon removal of the over-voltage condition, but the fuse may need to be replaced.

**Standard Cable Arrangement - RS-422****I/O Cable Color Code**

<b>Acutime Connection</b>	<b>Wire Color</b>	<b>Function</b>
Pin 1	Orange	Receive +
Pin 2	Brown	Transmit -
Pin 3	Yellow	Transmit +
Pin 4	Violet	Receive -
Pin 5	Blue	1pps/Memory Backup
Pin 6	Black	Ground
Pin 7	Red	Power

Use receive lines for DGPS correction inputs. Check individual protocols for interleaving method.

**Computer Interfacing - RS-422**

For connection to the RS-232 serial ports of most computers it is possible to wire the Acutime unit through an RS-422 - RS-232 converter. It is also possible for short runs to use a single ended RS-422 wired in the manner to a DB-25S plug.

CHAPTER EIGHT

Color	Function	DB-25S Pin
Violet	RX +	2
Brown	TX -	3
Orange	RX -	14
Yellow	TX +	16
Black	Ground 7	(Also power ground.)

**DC Connection**

Red                      Power + ve

This combination will operate both with and without the RS-422 - RS-232 converter *in most cases*. The exceptions are found with computers having UARTS with marginal voltage thresholds.

**Standard Cable Arrangement - RS-232**

Acutime Connection	Wire Color	Function
Pin 1	Violet	RXD 2 (DGPS coit. I/P)
Pin 2	Brown	RXD 1
Pin 3	Yellow	TXD 1
Pin 4	Orange	Signal Ground
Pin 5	Blue	1pps/Memory Backup
Pin 6	Black	Power Ground
Pin 7	Red	Power

**Note (1):** Connecting cable not normally supplied unless ordered specifically. Connector is standard seven pin male Conxall screw fitting mounted in the base of the housing. See below for part numbers.

**Note (2):** 1pps output is by pulldown of external voltage provided to open collector circuit through Pin 6. Pulse synchronized to the integer second on the falling edge. Leakage current of one-hundred microamps nominal taken to maintain internal memory.

**Dimensions*****Spigot Mount Antenna/Receiver, 18636-XX Series***

147 mm dia x 100 mm high (5.8" dia x 3.9" high) 3/4" NPT female spigot on bottom surface for mounting. Volume 1700 cc maximum (103 cubic inches) including dead space around mounting spigot.

***Flat Surface Antenna/Receiver, 18395-XX Series***

147 mm dia x 76 mm high (5.8" dia x 3.0" high) 7 each 18395-XX Series #4x40 female screwed fasteners on 119 mm (4.67") Pitch Circle Diameter on under surface - drilling template for mounting provided with each unit. Volume 1300 cc maximum (79 cubic inches).

***Weight***

0.41 Kg (0.9 pound)

**8.4 SYSTEM COMPONENT DESCRIPTION**

The Acutime GPS system consists of three units: the antenna, the receiver board, and a Lexan housing.

**Antenna/Preamplifier**

The antenna/preamplifier unit consists of a double dipole antenna element and preamplifier circuit within a single replaceable unit mounted together with the receiver board in a heavy duty Lexan housing complete with mounting cone (spigot mount) or screw inserts for flat surface mounting. The outside circumference of the housing is available for displaying a transfer of the client's logo, art work for which should be to client's account.

**Receiver Board**

The board consists of the necessary hardware and firmware required for satellite signal processing and solution computation. The receiver has six processing channels, operating on the L1 frequency using the C/A code. Prime DC power is supplied from an external source, with reasonable isolation against major in-line interference. The power supply module can tolerate variations between ten and thirty-two volts.

The GPS Acutime board receives the satellite signal through the antenna feedline connector. The complete process, from signal processing to digital output control, is performed by the components on the receiver board. The reference oscillator is a high-stability crystal oscillator operating at 16.368 MHz. The synthesizer module generates several signals for use on the board. One output is the local oscillator for the mixer. Two other frequencies are generated for use by the custom integrated circuits (ICs) tracking hardware. An additional signal is used as the microprocessor clock. The mixer has additional circuitry for coupling in the antenna signal. The IF module processes the IF signal, amplifying it and limiting its bandwidth. The resulting signal is fed to the signal processing circuits.

## CHAPTER EIGHT

The GPS tracking hardware is based on Trimble custom gate arrays. They contain satellite tracking circuitry, plus support circuitry for the microprocessor. The GPS Acutime has a single 16 bit microprocessor to perform both functions.

The channel signal processing circuits contain hardware for tracking the GPS satellite signals and for extracting the carrier code information as well as the navigation data at 50 bits per second. The signal processor controls the operation of the tracking hardware.

The receiver continuously tracks the four satellites used for a solution and uses the remaining channels to track up to four other satellites. The signal processor collects measurements and data, which are passed to the navigation processor module. The processor uses the measurements and data to compute the GPS based position and velocity solution. The navigation processor also controls the selection of which satellites are tracked and manages the orbital information data and almanac for all of the satellites.

### **Radio Frequency Interface**

GPS Acutime is designed to be functionally compatible with the L1 GPS satellite navigation signals as described in the GPS Specification SS-GPS-300B and ICD-GPS-200. GPS Acutime operates with the experimental Block I satellites as well as the operational Block II satellites or a combination thereof. GPS Acutime has burn-out protection which prevents damage by RF signals at frequencies which are 100MHz or more from the L1 frequency (1575.42 MHz), with received power up to one watt at the antenna.

## CHAPTER NINE

---

### PACKETS

#### 9.0 GENERAL

The following packets have been added to the bc627AT firmware.

#### 9.1 PACKET “M” - UTC LOCAL TIME OFFSET

This packet enables the unit to adjust UTC to the local time. The data input is in hours. The range of data is -12 to +12.

The packet format is as follows:

byte 1	SOH
byte 2	“M”
byte 3	ASCII “+”/”-“
byte 4	ASCII “0” - “1” (Hours Tens)
byte 5	ASCII “0” - “9” (Hours Units)
byte 6	ETB

#### 9.2 PACKET “N” - GPS LEAP SECONDS

This packet allows the user to load in the current number of GPS Leap Seconds. Leap seconds represent the time difference between GPS and UTC time. (GPS Time - UTC = leap seconds.) The current number of leap seconds is eight, as of February 1993, but this can change periodically. Reference Packet “O” to read GPS leap seconds from the unit.

Loading the unit with leap seconds is useful for faster UTC time acquisition. The GPS satellites present GPS time to the unit up to 12.5 minutes before GPS leap seconds are transmitted. If the user has the GPS leap seconds previously programmed, the unit can present UTC time as soon as GPS time is available.

This mode of operation is designated for UTC user’s only. GPS time users realize no benefit from this features. Reference Packet “P” to select UTC or GPS time mode. Reference Packet “O” to read the current leap seconds.



## CHAPTER NINE

The packet format is as follows:

byte 1	SOH
byte 2	“N”
byte 3	ASCII “0” - “1” (Seconds Tens)
byte 4	ASCII “0” - “9” (Seconds Units)
byte 5	ETB

### 9.3 PACKET “O” - REQUEST bc627AT DATA

This general purpose data request packet was added to allow the bc620AT to feed back key operation data to the host. Packet “O” is used to request data identified by the ID byte. In response, the unit returns Packet “i” with the requested data.

Packet format is as follows:

byte 1	SOH
byte 2	“O”
byte 3	id
byte 4	ETB

(id = “1” D/A Converter Control Voltage, and “2” GPS Leap Seconds.)

### 9.4 PACKET “o” - bc627AT DATA RETURN PACKET

This packet returns the data requested with Packet “O.”

Packet format is as follows:

byte 1	SOH
byte 2	“o”
byte 3	id
.	
.	
.	
byte	

id:

“1” D/A Converter Oscillatory Control Voltage Setting

byte 4 ASCII “O” - “F” (bits 12 through 15)

byte 5 ASCII “O” - “F” (bits 8 through 11)

byte 6 ASCII “O” - “F” (bits 4 through 7)

byte 7 ASCII “O” - “F” (bits 0 through 3)

“2” GPS Leap Seconds

byte 3 ASCII “0” - “9” (Second Tens)

byte 4 ASCII “0” - “9” (seconds Units)

## 9.5 PACKET “P” - PATH SELECTION

The term “path selection” might more appropriately be called switch selection or option control. The purpose of this packet is to create branch points in the bc620 firmware. The path packet contains 2 data bytes, each byte controls four switches, and each switch is assigned to a particular bit in the lower 4 bits of each byte. The upper 4 bits of each byte are set to 3. The default settings are all switches set to zero *except* the diagnostics bit which is set to one. The format is as follows:

byte 1	SOH
byte 2	“P”
byte 3	Data A (See Below)
byte 4	Data B (See Below)
byte n	ETB

### Data A

Bit 0	0 = Disable FIFO Echo	1 = Enable FIFO Echo
Bit 1	0 = UTC Time	1 = GPS Time
Bit 2	0 = Not Used	
Bit 3	0 = Normal BCD Time Format	1 = Long Seconds

### Data B

Bit 0	0 = Diagnostics On	1 = Diagnostics Off
Bit 1	0 = Leap Year Off	1 = Leap Year On
Bit 2	0 = Enable Jamsynchs	1 = Disable Jamsynchs
Bit 3	0 = Enable Disciplining	1 = Disable Disciplining

This Page Intentionally Left Blank.

## CHAPTER TEN

---

### ANTENNA MOUNTING

#### 10.0 ANTENNA MOUNTING

Choose a location for the antenna/receiver as close as possible to vertical, which has a relatively unobstructed view of the horizon, and which will be safe from damage during normal operation of the host vehicle. Dense wood or metal structures will shield the antenna/receiver from satellite signals. The Acutime can receive satellite signals through glass, canvas, and thin fiberglass. If you plan to install the unit in a partially enclosed environment, test the ability of the Acutime to receive satellite signals before committing to a permanent mount. The unit is designed to withstand the full rigors of the elements and can be mounted in an exposed external location. The only limitation is that the unit's extended performance at temperatures below -40° (C or F) is not warranted. The unit will perform also when partially snow covered, provided the snow is dry. Ice accumulations will eventually shut off performance, only if the ice sheet is continuous. The shape of the unit has been selected partially to minimize rain, snow, and ice accumulation.

The antenna/receiver is an active head antenna. For optimal performance, avoid locating the Acutime within two feet (sixty centimeters) of other antennas, near high vibration areas like engine housings, or near radar installations. If there is a limitation on available mounting locations, ensure at least that the Acutime is position outside the radar's cone of transmission. Follow the same guidelines when installing the Acutime near satellite communication equipment (e.g., Inmarsat A or C) or microwave dishes. For best results, mount the Acutime below and at least ten feet (three meters) away from satellite communication equipment.

If the unit is being mounted permanently in a microwave installation, e.g., for timing purposes, then care should be exercised to shield the unit from random back-scatter from microwave dishes. Difficulties will be immediately apparent if the unit cannot lock on to satellites or shows a poor ability to track. Protection is afforded by use of ground plane, a metallic shield which is mounted below the desired minimum viewing angle of the antenna unit. In extreme cases, a cone shield extending up to a ten degree horizontal viewing angle may be tried (make allowance for snow and rain drainage). This takes advantage of the fact that low elevation satellites have lowers signal/noise ratios due to increased ionospheric absorption and therefore are less desirable for timing purposes. Such a cone shield will not work well on a moving vehicle such as a vessel because of it's rolling and pitching motion.

## CHAPTER TEN

The Acutime is designated for a pole mount. The threaded socket at the base of the Acutime will accept both a 1" - 14 threads per inch (TPI) straight thread, and a standard ¾" - 14 TPI (NPT) pipe thread. The Acutime only requires hand tightening on the pole mount. For temporary installations on a metallic surface, a magnetic mount may be used (part number 12920-00) together with an adapter (part number 17030). The adapter is threaded 5/8 11 (TPI), the standard survey instrument mounting thread.

The connector cable should be firmly secured to the support using cable ties so that there is little or no mechanical strain on the seven pin connector.

**Note:** The Acutime is a valuable instrument and for permanent installations it may be prudent to drill and pin the Acutime mount to discourage theft and prevent accidental loosening. If the Acutime is easily removed, store it in a secure location when not in use.



SYMMETRICOM TIMING & TEST  
MEASUREMENT  
3750 Westwind Blvd.  
Santa Rosa, California 95403 USA  
Tel: 707-528-1230  
Fax: 707-527-6640  
[info@symmetricom.com](mailto:info@symmetricom.com)  
[www.symmetricom.com](http://www.symmetricom.com)

For more information about the complete range of Quality  
Timing Products from the Symmetricom group of companies  
call 1-800-544-0233 in the US and Canada.

Or visit our site on the world wide web at  
<http://www.Symmetricom.com> for continuously updated  
product specifications, news and information.